

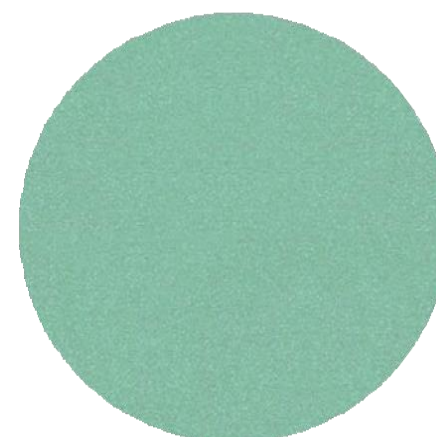

SELECTION GAMME LUXE MEUBLES DE SALLE DE BAIN

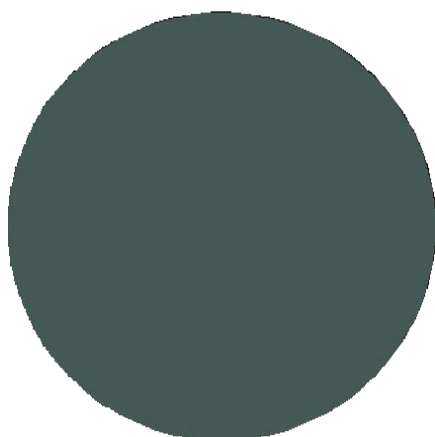

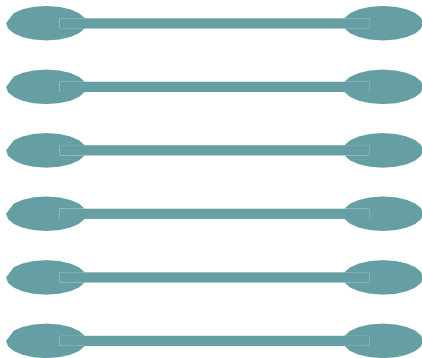
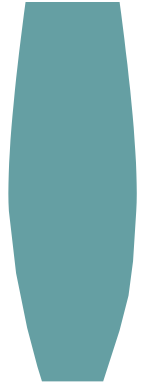
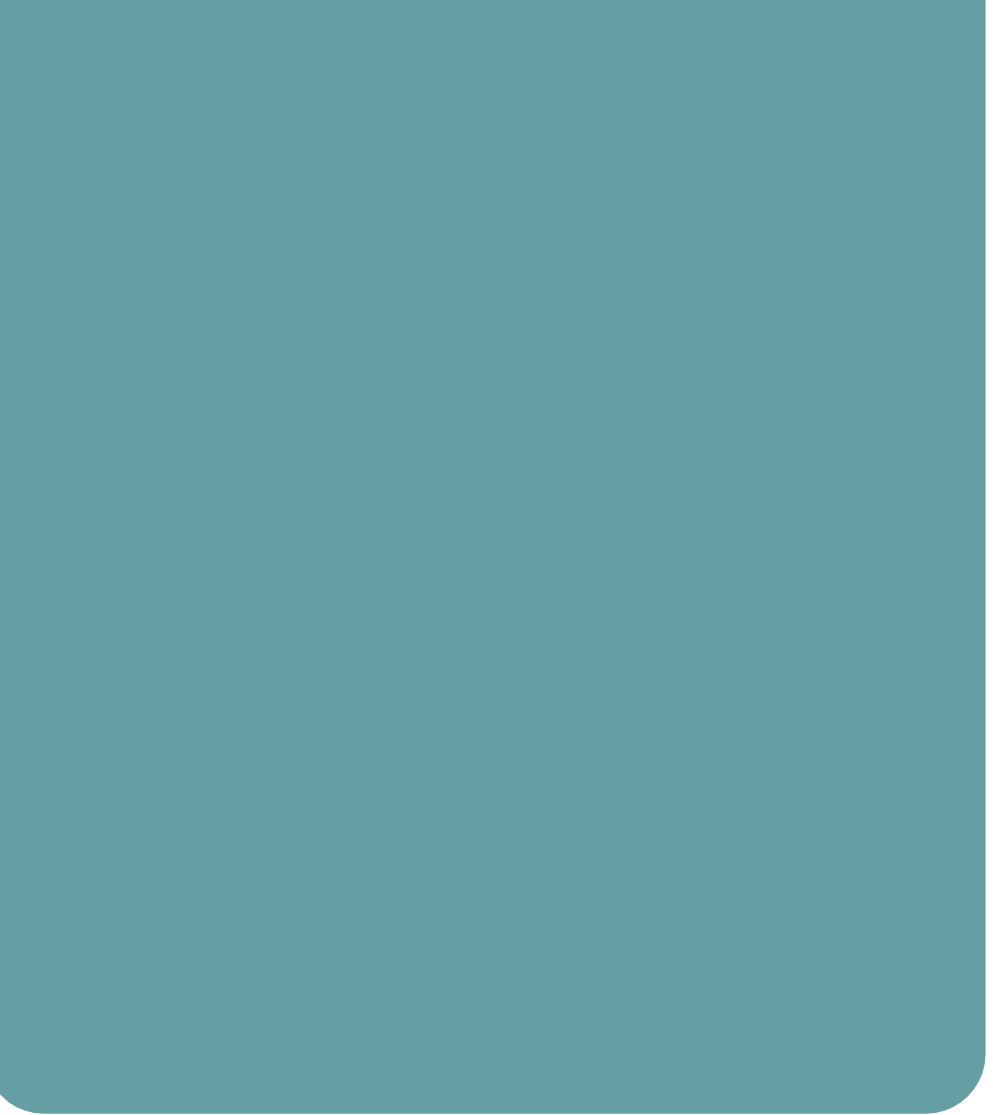

pino
baños

Al sur de España, en Andalucía y al este de la ciudad de Córdoba se encuentra la localidad de Villafranca, donde se ubican las instalaciones que **PINO Cocinas & Baños** utiliza desde 1995.

En la actualidad somos una sociedad, de carácter familiar, gestionada por la segunda generación. Contamos con una plantilla de más de 60 personas con una media de edad de entre 30 y 40 años. Juventud, experiencia y profesionalidad se unen con el objetivo de prestar la mejor de las atenciones, proporcionar un servicio eficaz y ofrecer un producto de calidad, acorde con las nuevas tendencias y a un precio siempre asequible e interesante.

La organización tiene como objetivo primordial la calidad y el valor añadido y para ello se ha invertido en la más avanzada tecnología durante los últimos años. Eso nos ha posicionado como una de las primeras empresas del sector en nuestro país con más de 55.000 m² preparados con la maquinaria más moderna, una organización abierta y dinámica, respetuosa con el Medio Ambiente y comprometida con el desarrollo de la región y la calidad de vida de sus miembros.

Consideramos a nuestra clientela parte de la organización, ya que nos une a ella una relación duradera y estable que consideramos la mejor garantía de nuestra profesionalidad. Nuestra capacidad de adaptarnos a sus necesidades y nuestro apoyo constante es lo que nos diferencia de nuestra competencia en un panorama general en el que calidad, precio y servicio se dan por sentado y no deben ser valores de distinción. La venta de nuestros productos abarca todo el mercado nacional y opera en zonas concretas de Portugal, Francia, América Latina, Qatar y Pakistán; entre otros mercados en los que nos encontramos en plena expansión.





In Andalusia, southern region of Spain we have the town of Villafranca of Cordoba, where **PINO Cocinas & Baños** uses their current facilities since 1995.

Currently we are a family owned company managed by the second generation. We count with a staff of more than 60 people with an average age among 30 and 40 years. Youth, experience and professionalism meets with a target of offering the best custom care, an efficient service, a quality product according to the new tendencies and on an affordable price.

Our company has the main priority, the concern about the quality and the added value; and to make it happen we have invested in the most advanced technology during the last years. With more than **55.000 m²** prepared with the latest machinery, an open and dynamic organization, respectful with the environment and committed with the region's and its members development; has positioned us as one of the pioneers company among our sector in our country.

We consider our clientage part of us, as we are joint by a long-lasting and stable relationship which is the best guarantee of our professionalism. Our capacity of adaptation to your needs and our constant support is what makes us different from our competitors in a general panorama where quality, price and service are taken for granted and should not be considered as a fact of distinction. Our network covers the whole national market and operates in specific markets of Portugal, France, South America, Qatar, and Pakistan among others where we are in full expansion.

Au Sud de l'Espagne, en Andalousie et à l'Est de la ville de Cordoue se situe Villafranca, où se trouvent les locaux que PINO Cocinas & Baños utilise depuis 1995.

Nous sommes une société familiale, gérée actuellement par la deuxième génération. Notre personnel est composé de plus de 60 personnes, dont la moyenne d'âge est comprise entre 30 et 40 ans. Jeunesse, expérience et professionnalisme sont réunis dans l'objectif de répondre aux clients de la meilleure façon possible, de proportionner un service efficace et de proposer un produit de qualité, selon les nouvelles tendances et à un prix toujours accessible et intéressant.

Les objectifs principaux de notre société sont la qualité et la valeur ajoutée. Nous avons dans ce but investi dans une des technologies les plus avancées au cours des dernières années. Ceci nous a situé parmi les entreprises en tête de liste de notre pays, avec plus de 55,000 m² aménagés avec les machines les plus modernes, une organisation ouverte d'esprit et dynamique, respectueuse de l'environnement, impliquée dans le développement de la région et la qualité de vie de ses membres.

Nous considérons notre clientèle comme partie de notre société, nous sommes unis à nos clients par une relation durable et stable, ce qui constitue la garantie de professionnalisme la plus solide. Notre capacité d'adaptation à vos besoins et notre soutien constant marquent la différence par rapport à la concurrence, car la qualité, le prix et le service vont de soi et ne sont pas des valeurs de distinction. Nos produits sont vendus sur tout le marché national et au niveau international dans des zones concrètes de Portugal, France, Amérique Latine, Qatar et Pakistan; des marchés sur lesquels nous nous trouvons en pleine expansion.

CONDICIONES GENERALES

- Todos los artículos de esta tarifa están valorados en puntos. El precio final será el resultado de aplicar un factor de conversión a estos puntos. El factor de conversión será facilitado por PINO.
- Los términos de pago y las condiciones económicas se acordarán entre PINO y cada cliente.
- Los puntos mencionados en este catálogo se basan en términos Ex Works Villafranca de Córdoba (España).
- PINO se reserva el derecho de introducir todas aquellas modificaciones que la empresa crea oportunas para mejorar nuestro producto y nuestra organización.
- PINO no se responsabiliza de los errores que puedan surgir en la impresión y composición de este catálogo.
- Esta tarifa anula a todas las anteriores.
- Ante un eventual problema de falta de entendimiento y si no es posible su solución por los cauces comerciales habituales, las partes se someterán a los juzgados y tribunales de Córdoba, renunciando a cualquier otro fuero.

GENERAL CONDITIONS

- All articles mentioned in this price list are in points. The final price will be the result of applying the conversion factor to these points. This factor will be provided by PINO.
- The payment terms and economic conditions will be agreed and set among PINO and each client.
- The points mentioned in the catalogue are based in terms Ex Works Villafranca de Córdoba (Spain).
- PINO has the right to introduce all those modifications which we consider convenient to improve our product and company.
- PINO is not responsible for any mistake that may arise from the printing and/or in the composition of this catalogue.
- This catalogue invalidate all other versions.
- To a possible problem of lack of understanding and if its solution is not possible by the common commercial channels, both parties will be submitted to the courts of Cordoba, Spain, waiving any other jurisdiction.

CONDITIONS GÉNÉRALES

- Tous les prix de ce tarif sont en points. Le prix final sera le résultat de l'application d'un facteur de conversion au montant en points. Ce facteur de conversion sera facilité par PINO.
- Les conditions économiques et le mode de paiement seront convenus entre PINO et chaque client.
- Les nombres de points indiqués sur ce catalogue sont Ex Works Villafranca de Córdoba (Espagne).
- PINO se réserve le droit d'apporter toutes modifications estimées opportunes afin d'améliorer nos produits et notre organisation.
- PINO ne sera responsable d'aucune erreur d'impression ou composition de ce catalogue.
- Ce catalogue annule tous les tarifs antérieurs.
- En cas de désaccord et dans l'impossibilité de trouver une solution amiable, les parties seront soumises aux tribunaux de Cordoue, en renonçant à toute autre juridiction.

PLAZOS DE FABRICACIÓN GENERALES

GENERAL MANUFACTURING DATE

DÉLAIS DE FABRICATION GÉNÉRAUX

LAMINADOS DE ALTA Y BAJA PRESIÓN	15 DÍAS (Laborables según calendario Pino)	HIGH AND LOW PRESSURE LAMINATES	15 DAYS (As per Pino's working days calendar)	MÉLAMINE ET STRATIFIÉ	15 JOURS (ouvrables selon le calendrier PINO)
LACA, MADERA Y SERIGRAFÍA	25 DÍAS (Laborables según calendario Pino)	LACQUER, WOOD AND SCREEN PRINTS	25 DAYS (As per Pino's working days calendar)	LAQUE, BOIS ET SÉRIGRAPHIE	25 JOURS (ouvrables selon le calendrier PINO)

Nota: estos plazos empiezan a contar desde la confirmación del pedido con el cliente y no desde la recepción del mismo. Estas fechas no incluyen la duración del transporte.

Note: These dates starts counting from the date of confirmation of the order and not from its reception. These dates do NOT include the delivery duration.

Remarque: ces délais commencent à partir de la date de confirmation de la commande et n'incluent pas la durée du transport.

NORMAS DE PEDIDO

No se admitirán reclamaciones de pedidos que no se hayan solicitado teniendo en cuenta las siguientes normas:

- El pedido será cursado a fábrica por escrito (vía fax o e-mail) para que quede constancia del mismo.
- Serán necesario enviar una relación de la mercancía detallando todas las especificaciones y aclaraciones para el buen entendimiento del mismo.
- Los pedidos deberán ser aclarados con la mayor brevedad posible teniendo la fecha de aclarado como referencia para el cómputo del plazo de entrega.

Importante: una vez aclarado el pedido, será cursado a fábrica, por lo que no se admitirá modificación alguna desde la confirmación de pedido. Para cualquier modificación posterior se tendrá que cursar un nuevo pedido y asumir los gastos derivados de la anulación del pedido original.

NORMAS DE DEVOLUCIÓN

- Salvo error probado por nuestra parte, no se admitirá devolución alguna de material a fábrica.
- Todo el material que se devuelva a fábrica necesitará la nota de recogida previa, elaborada en nuestra empresa. El personal de transporte no retirará nada que no tenga la correspondiente nota. No nos haremos responsables de la mercancía que se reciba sin identificar.
- No se admitirá material en concepto de devolución una vez transcurridos 60 días desde la fecha de entrega del material.

VALORACIÓN DE ESPECIALES

Todo mueble que no se encuentre dentro de este catálogo por diseño, medida, o acabado se considerará especial.

- Los criterios de valoración de especiales serán los siguientes:
 - Medida especial sobre plantilla estándar de mueble y espejos:
 - Reducir alguna de las medidas en alto, ancho y fondo: 0%
 - Ampliar alguna medida en alto, ancho, fondo: 35%
 - Desplazar salvasifón: 2840 puntos.
 - Módulo sobredimensionado. Aquel que excede de la medida estándar mayor disponible: 50 %
 - Color especial de laca: 10%

RULES TO ORDER

No claim of orders will be accepted if the following rules have not been followed:

- The order will be sent to the factory in written (by fax or e mail) for its record.
- It will be necessary to send a list of UNITS detailing all specifications and explanations for a correct comprehension of the same.
- The order should be clarified and confirmed at the earliest, as the delivery date will be set according to the confirmation date.

Important: Once the order is confirmed, it will be processed to the factory, so no modification will be allowed since its confirmation. For any further changes, it will be considered as a new order and the client will bear with its cost.

RETURN POLICY

- Except a mistake proven by our side, no replacement of material will be permitted.
- All material returned to the factory needs a previous collection note generated by us. The transport company will not collect anything without this note. We will not be responsible for any material not identified correctly.
- No material shall be allowed to be returned after 60 days from its delivery date.

SPECIAL UNITS VALUATION

Any unit which is not present in this catalogue for its design, measure or finish will be considered as special.

- The criterias for special UNITS valuation are:
- Special measure over standard UNITS:
 - Reduce some of the measures in height, width and depth: 0%
 - Enlarge some of the measures in height, width and depth: 35%
- Shift trap protection: 2840 points
- Special lacquer colour: 10%

RÈGLEMENTATION DES COMMANDES

Nous n'admettons aucune réclamation de commande ayant été passée en dehors des normes mentionnées ci-dessous.

- La commande sera passée par écrit au département export.
- Vous devrez envoyer une liste détaillée de toutes les spécifications des éléments souhaités, afin d'éviter quelconque malentendu.
- Le département export vous enverra une confirmation de commande que vous devrez nous envoyer par retour au plus vite avec votre validation. Cette date comptera comme point de départ pour le délai de livraison.

Important : une fois la commande confirmée, elle sera passée à fabrication, de sorte qu'aucune modification ne sera acceptée à partir de ce moment-là. Pour toute modification ultérieure, vous devrez passer une nouvelle commande et prendre en charge les frais occasionnés.

RÈGLEMENTATION DES RETOURS ET SAV

- Aucun matériel ne pourra être restitué à l'usine ou remplacé, sauf s'il s'agit d'une erreur prouvée de notre part. Chaque incidence donnera lieu à une réclamation, avec des photos à l'appui.
- Tout matériel retourné à l'usine devra être accompagné d'une note d'enlèvement élaborée par le département export. Le personnel de transport ne reprendra rien sans la note d'enlèvement correspondante. Nous ne prendrons en charge aucune marchandise non identifiée.
- Aucun retour ni SAV ne sera admis dans un délai supérieur à 60 jours à compter de la date de livraison de la marchandise.

CHIFFRAGE DES MEUBLES SUR MESURE

Tout meuble qui ne se trouve pas dans ce catalogue quant à design, dimensions ou finition sera considéré spécial.

- Les critères d'évaluation des meubles spéciaux seront les suivants: Design: notre département technique étudiera la possibilité de fabrication et chiffrera le meuble modifié.
- Dimensions spéciales par rapport à nos standards:
 - Réduire une des dimensions, que ce soit la hauteur, la largeur ou la longueur: 0%
 - Augmenter une des dimensions, que ce soit la hauteur, la largeur ou la longueur: 35%
- Déplacer la découpe du siphon: 2.840 points.
- Finition spéciale laques: 10%

LÍNEA CAPRICH0			09
AFRODITA			10
ARTEMIS			14
ATENEA			18
CUBO			22
HERA			26
MIMOSA			30
LÍNEA ESTILO			35
BEATRIZ			36
BIANCA			40
CARLA			44
DAVO			48
ON			52
TAO			56
AUXILIARES	AUXILIARY UNITS	MEUBLES AUXILIAIRES	61
COLUMNA	COLUMNS	COLONNE	62
MEDIA COLUMNA	SEMICOLUM	DEMI COLONNE	63
COLGARES	WALL UNITS	MEUBLES SUSPENDUS	64
DECORATIVOS	DECORATIVES	MEUBLES DECORATIFS	65
ACABADOS	FINISHES	FINITIONS	67
SERIGRAFÍAS	SCREEN PRINTS	SÉRIGRAPHIES	73
EQUIPAMIENTO Y COMPLEMENTOS			
	EQUIPMENT AND COMPLEMENTS		
	ACCESSOIRES ET COMPLÉMENTS		79

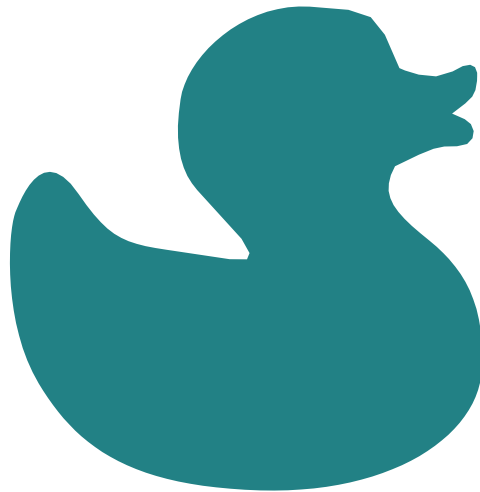

Ligne
Collection
Línea

CAPRICHO

Los mejores acabados.
Los mejores materiales.

The best finishes.
The best materials.

Les meilleures finitions.
Les meilleurs matériaux.

Afrodita



AFRODITA representa las líneas más románticas y actuales. Presentado en color blanco, el modelo recupera toda la calidez de tiempos pasados, pero puestos al día para aportar toda la funcionalidad y el confort que deseas en los elementos que componen tu hogar.



AFRODITA represents the most romantic and trendy lines. Presented in white, it recovers all the warmth of the past but in a refreshed version, providing you all the functionality and comfort you need to be present in each and every element of your home.

AFRODITA représente les lignes de produits les plus romantiques et actuels. Par exemple en blanc, ce modèle récupère un aspect chaleureux comme d'antan, tout en apportant la fonctionnalité et le confort demandés de nos jours.



 Grupo Laca
Blanco Mate

Afrodita

MUEBLE
UNIT
MEUBLE

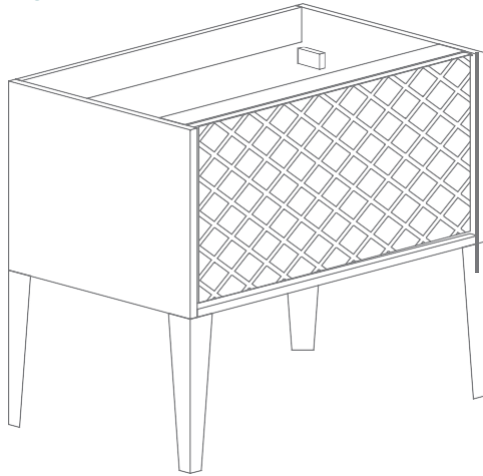

ALZADO
LAY OUT
PLAN PROFIL

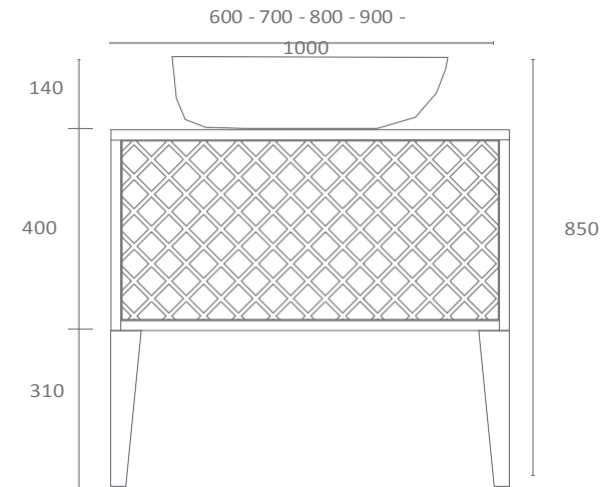
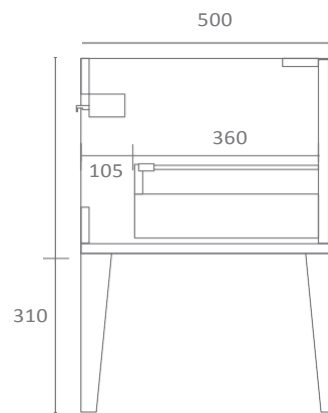

MEDIA COLUMNA
SEMI COLUMN
DEMI COLONNE

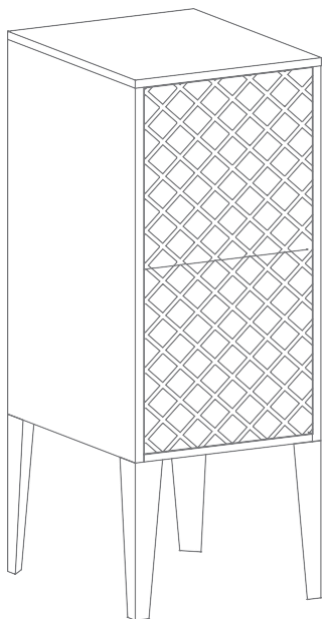

ALZADO
LAY OUT
PLAN PROFIL

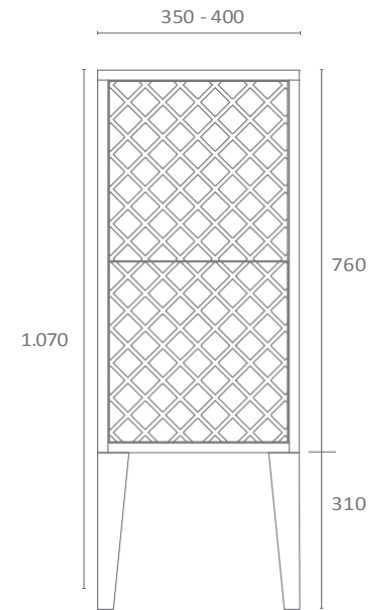
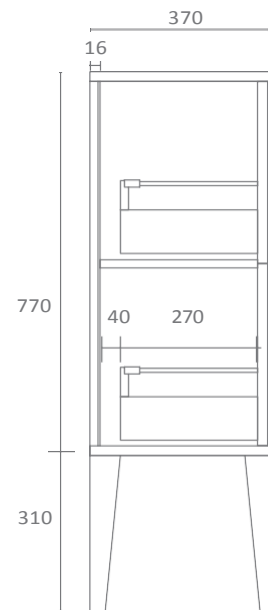

DESCRIPCIÓN DESCRIPTION DESCRIPTION	CARACTERÍSTICAS CHARACTERISTICS CARACTÉRISTIQUES	MEDIDAS (Ancho x Alto x Fondo) MEASUREMENTS (Width x Height x Depth) DIMENSIONS (Largeur x Hauteur x Profondeur)	LACA Mate y Texturado MATT LACQUER (and Textured) LAQUE Mate et avec texture	LACA Brillo y Engomado GLOSSY LACQUER (and Rubber finish) LAQUE Brillant et effet gomme
Afrodita * con sistema de apertura Push. with Push open system avec système Push-Pull	Mueble suspendido con contenedor Wall Unit with big drawer Meuble suspendu avec tiroir	600 x 400 x 500 mm	Precios sin tapa incorporada Prices without top Prix sans plateau incorporé	
		700 x 400 x 500 mm		
		800 x 400 x 500 mm		
		900 x 400 x 500 mm		
		1000 x 400 x 500 mm		
	Tapa Top Plateau meuble	605 x 510 mm	Precios tapa Top prices Prix du plateau	
		705 x 510 mm		
		805 x 510 mm		
		905 x 510 mm		
		1005 x 510 mm		
	Calado tapa para lavabo Basin cut in the top Découpe vasque sur plateau	Precio del calado de la tapa Basin cut in the top price Prix de la découpe du plateau		
Media Columna Afrodita con sistema de apertura Push. Semi Column with push open system Demi colonne avec système Push-Pull	Media columna suspendido y con 2 contenedores verticales Wall mounted Semi Column with 2 vertical big drawers. Demi colonne suspendue avec deux tiroirs verticaux	350 x 760 x 370 mm		
		400 x 760 x 370 mm		
Pata Afrodita Leg Pied	Pata en L (juego de 4 unidades) Set of 4 units Jeu de 4 pieds	310 mm		
Lavabo Nettuno 550 Basin Nettuno Vasque Nettuno	Lavabo cerámico sobreencimera Over countertop ceramic basin Vasque céramique sur plan de travail	550 x 140 x 405 mm		

* Este mueble no es apto para nuestro lavabo de encastre.
This unit is not suitable for integrated basin.
Ce meuble ne convient pas pour notre vasque encastrée.

Artemis

El modelo ARTEMIS representa la elegancia obtenida a partir de líneas minimalistas. Un estilo depurado que encaja en cualquier ambiente y que apuesta por la belleza dotada de las máximas prestaciones para disfrutar el día a día.



ARTEMIS represents the elegance obtained from minimalist lines. A refined style which fits into every environment and commits to offer the maximum performance day by day, despite its beauty.

Le modèle ARTEMIS représente l'élégance résultant de lignes minimalistes. Un style raffiné qui s'adapte à toutes les ambiances. Beauté et prestations maximales sont réunies pour profiter de votre salle de bain au quotidien.



Grupo B
Cuatro 3091



 Grupo B
Seissa 1102

Artemis

MUEBLE
UNIT
MEUBLE

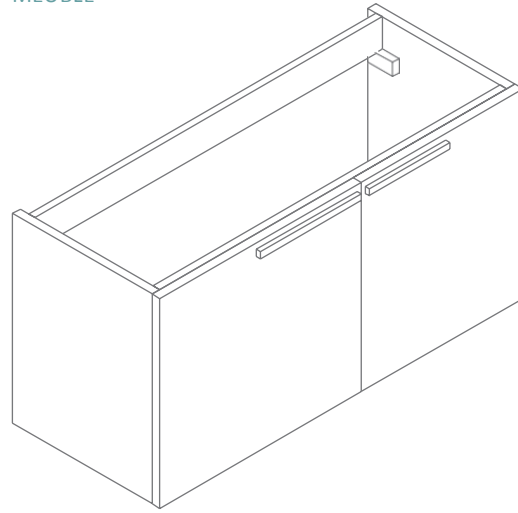

ALZADO
LAY OUT
PLAN PROFIL

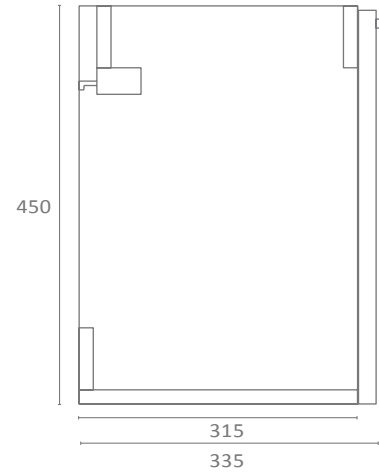

FRONTAL 700
FRONT SIDE
FAÇADE

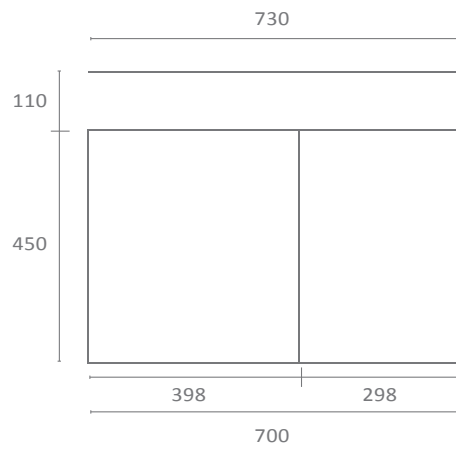

FRONTAL 900
FRONT SIDE
FAÇADE

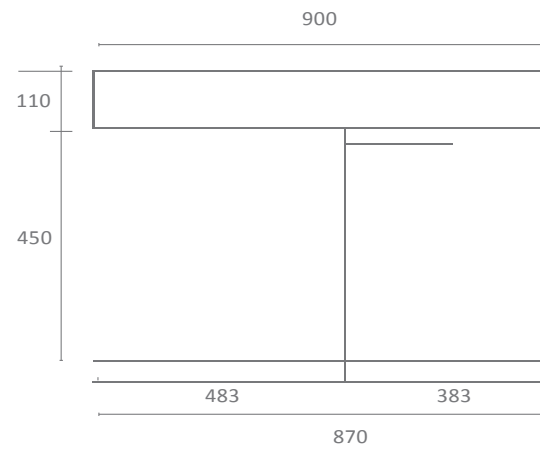

FRONTAL 1000
FRONT SIDE
FAÇADE

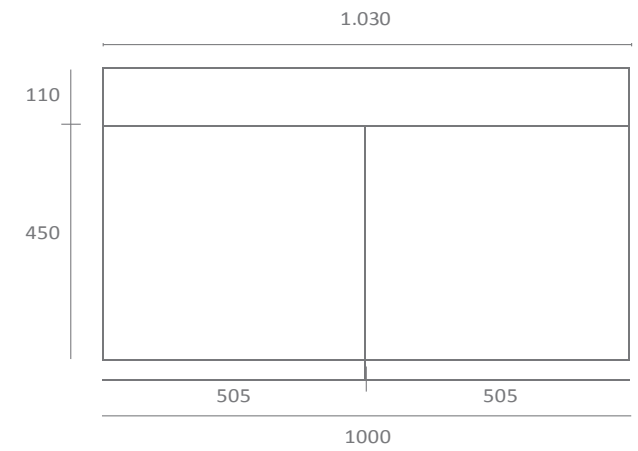

DESCRIPCIÓN DESCRIPTION DESCRIPTION	CARACTERÍSTICAS CHARACTERISTICS CARACTERISTIQUES	MEDIDAS (Ancho x Alto x Fondo) MEASUREMENTS (Width x Height x Depth) DIMENSIONS (Largeur x Hauteur x Profondeur)	GRUPO GROUP GROUPE A	GRUPO GROUP GROUPE B	GRUPO GROUP GROUPE C	LACA Mate y Texturado MATT LACQUER (and Textured) LAQUE Mate et avec texture	LACA Brillo y Engomado GLOSSY LACQUER (and Rubber finish) LAQUE Brillant et effet gomme
	Mueble 1Puerta Izda. 400 / 1P Dcha. 300 Unit 1Left Door 400 / 1Right Door 300 Meuble 1 porte gauche de 400 / 1 porte droite de 300	700 x 450 x 335 mm					
Artemis	Mueble 1P Izda. 485 / 1P Dcha. 385 Unit 1Left Door 485 / 1Right Door 385 Meuble 1 porte gauche de 485 / 1 porte droite de 385	870 x 450 x 335 mm					
	Mueble 1P Izda. 500 / 1P Dcha. 500 Unit 1Left Door 500 / 1Right Door 500 Meuble 1 porte gauche de 500 / 1 porte droite de 500	1000 x 450 x 335 mm					
Lavabo Naos Faucet Naos Vasque	Grifo siempre a la derecha. Faucet always on right. Mitigeur toujours à droite	730 x 110 x 350 mm 900 x 110 x 350 mm 1030 x 110 x 350 mm					

Atenea

Volúmenes geométricos, líneas atemporales, elegantes, minimalistas... el modelo ATENEA ha llegado para completar el círculo entre la máxima funcionalidad y el diseño.

Geometric shapes, timeless, elegant, minimalist lines... ATENEA has arrived to complete the connection between the maximum functionality and the design.

Volumes géométriques, lignes intemporelles, élégantes, minimalistes, etc. Le modèle ATENEA complète la ligne de produits qui regroupe la fonctionnalité maximale et le design.





 Grupo Laca
Brillo Negro

Atenea

MUEBLE 1 CONTENEDOR
LAY OUT WITH 1 BIG DRAWER
PLAN PROFIL AVEC 1 TIROIR

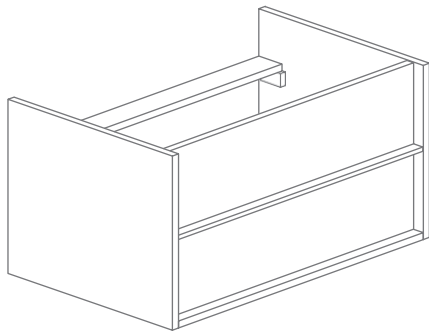

ALZADO
LAY OUT
PLAN PROFIL

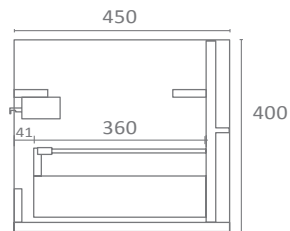

FRONTAL
FRONT SIDE
FAÇADE

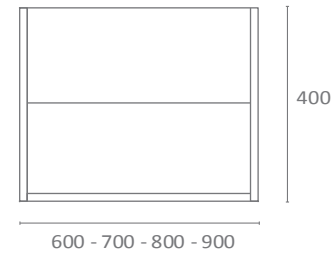

ALZADO
LAY OUT
PLAN PROFIL

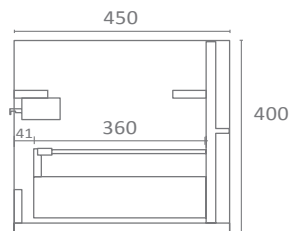

FRONTAL DE 3 CONTENEDORES
FRONT SIDE WITH 3 BIG DRAWER
FAÇADE AVEC 3 TIROIRS

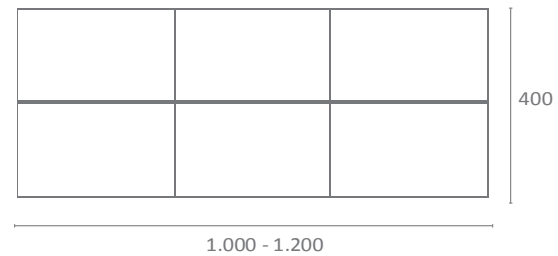

En ancho 1200 sólo para lavabo de 1 seno
In 1200 mm width only for 1 bowl basin
En 1200 de large senlement pour plan 1 vasque

MEDIA COLUMNA
SEMI COLUMN
DEMI COLONNE

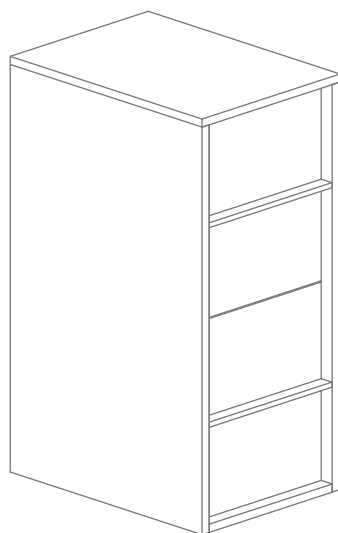

ALZADO MEDIA COLUMNA
SEMI COLUMN LAY OUT
DEMI COLONNE PLAN PROFIL

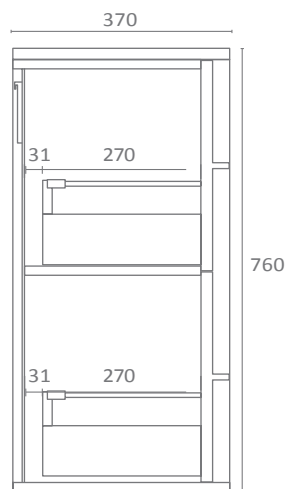

FRONTAL MEDIA COLUMNA
SEMI COLUMN FRONT SIDE
DEMI COLONNE FAÇADE

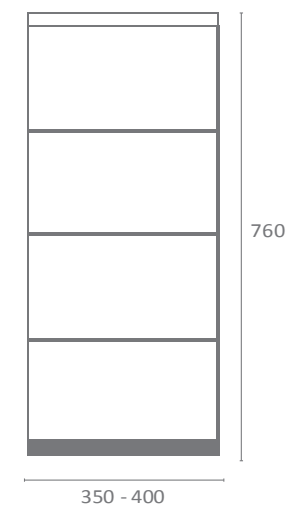

DESCRIPCIÓN DESCRIPTION DESCRIPTION	CARACTERÍSTICAS CHARACTERISTICS CARACTÉRISTIQUES	MEDIDAS (Ancho x Alto x Fondo) MEASUREMENTS (Width x Height x Depth) DIMENSIONS (Largeur x Hauteur x Profondeur)	LACA Mate y Texturado MATT LACQUER (and Textured) LAQUE Mate et avec texture	LACA Brillo y Engomado GLOSSY LACQUER (and Rubber finish) LAQUE Brillant et effet gomme
Atenea	Mueble con 1 contenedor Unit with 1 big drawer Meuble avec 1 tiroir	600 x 400 x 450 mm		
		700 x 400 x 450 mm		
		800 x 400 x 450 mm		
	Mueble con 3 contenedores* Unit with 3 big drawer Meuble avec 3 tiroir	900 x 400 x 450 mm		
		1000 x 400 x 450 mm		
		1200 x 400 x 450 mm		
Tapa Top Plateau meuble		605 x 460 mm		
		705 x 460 mm		
		805 x 460 mm		
		905 x 460 mm		
		1005 x 460 mm		
		1205 x 460 mm		
	Calado tapa para lavabo Basin cut in the top Découpe vasque sur plateau		444	
Media Columna Atenea	2 contenedores verticales 2 vertical big drawers 2 tiroirs verticaux	350 x 760 x 370 mm		
		400 x 760 x 370 mm		

* Mueble con 3 contenedores: En ancho 1200 sólo para lavabo de 1 seno

* Unit with 3 big drawers: In 1200 mm width only for 1 bowl basin

* Meuble 3 tiroirs: En 1200 de large seulement pour plan 1 vasque.

Cubo

Inventa tu propio baño.
Con la serie CUBO no tienes límite.

Invent your own bath.
With the collection CUBO there is no limit.

Inventez votre propre salle de bain.
Avec la série CUBO vous n'aurez aucune limite.

 Grupo B
Seissa 1100

 Grupo A
Mecuo 93



Grupo B
Meidass 41

Grupo Laca Mate Platino

cubo

MUEBLE
UNIT
MEUBLE

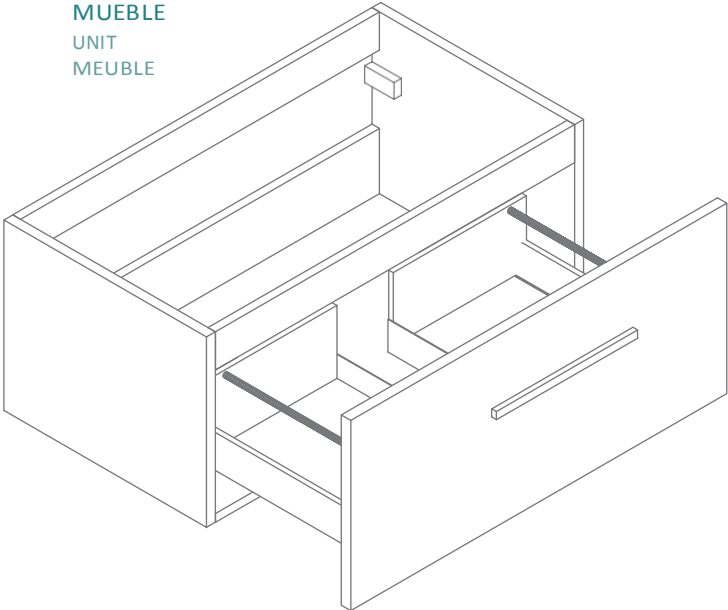

ALZADO DERECHO
RIGHT LAY OUT
PLAN PROFIL DROIT

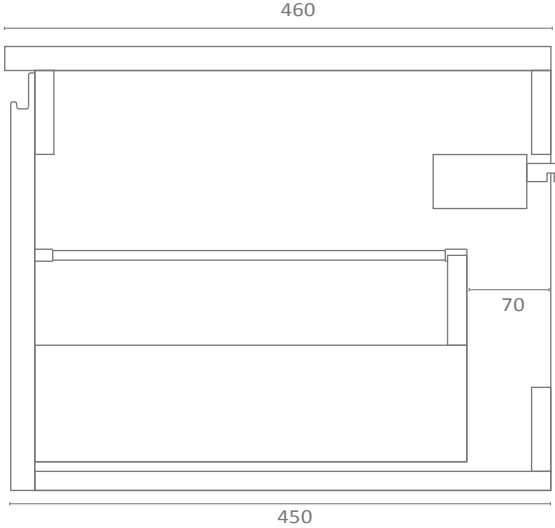

ALZADO DERECHO CUBO CERRADO
RIGHT LAY OUT CLOSED CUBO
PLAN PROFIL DROIT CUBO FERMÉ

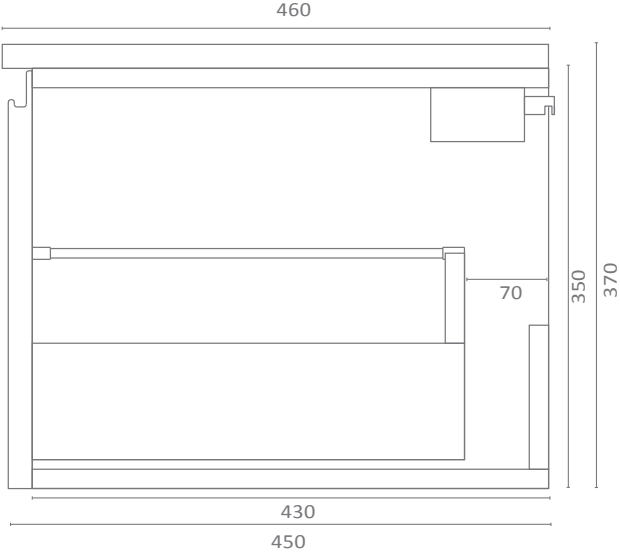

FRONTAL
FRONT SIDE
FAÇADE



400 - 500 - 600 - 700 - 800 - 900 - 1000 - 1200

DESCRIPCIÓN DESCRIPTION DESCRIPTION	CARACTERÍSTICAS CHARACTERISTICS CARACTÉRISTIQUES	MEDIDAS (Ancho x Alto x Fondo) MEASUREMENTS (Width x Height x Depth) DIMENSIONS (Largeur x Hauteur x Profondeur)	GRUPO GROUP GROUPE A	GRUPO GROUP GROUPE B	GRUPO GROUP GROUPE C	LACA Mate y Texturado MATT LACQUER (and Textured) LAQUE Mate et avec texture	LACA Brillo y Engomado GLOSSY LACQUER (and Rubber finish) LAQUE Brillant et effet gomme
		400 x 350 x 450 mm					
		500 x 350 x 450 mm					
		600 x 350 x 450 mm					
	Mueble suspendido con contenedor y salvafón Wall Unit with big drawer and trap protection Meuble suspendu avec tiroir et découpe siphon	700 x 350 x 450 mm					
		800 x 350 x 450 mm					
	Nota: Especificar si no se quiere el salvafón. Note: Specify if trap protection is not required. Remarque: Veuillez préciser si vous ne souhaitez pas la découpe du siphon	900 x 350 x 450 mm					
		1000 x 350 x 450 mm					
		1200 x 350 x 450 mm					
	Mueble suspendido con contenedor doble seno Wall Unit with big drawer double bowls Meuble suspendu avec tiroir et vasque double	1200 x 350 x 450 mm					
		405 x 460 mm					
		505 x 460 mm					
		605 x 460 mm					
	Tapa Top Plateau meuble	705 x 460 mm					
Cubo		805 x 460 mm					
		905 x 460 mm					
		1005 x 460 mm					
		1205 x 460 mm					
	Calado tapa para lavabo Basin cut in the top Découpe vasque sur plateau	400 mm					
		500 mm					
		600 mm					
		700 mm					
	Tirador T-22 Handle T-22 Poignée T22	800 mm					
		900 mm					
		1200 mm					
		80 x 80 altura 30					
		80 x 30 x 80 mm					
		100 x 100 altura 20					
		100 x 20 x 100 mm					
	Juego de patas Legs set Jeu de pieds	Altura 100 mm Brillo					
		35 x 100 x 35 mm					
		Altura 120 mm Brillo / Mate					
		35 x 120 x 35 mm					
		Altura 200 mm Mate					
		35 x 200 x 35 mm					

Hera

HERA está concebido para disfrutar.

Piezas mucho más amplias y espaciosas, diseñadas para dar respuesta a múltiples necesidades.

Opciones de gran solvencia para crear atmósferas de bienestar, equilibradas y bien resueltas.

HERA is designed to enjoy. Much more spacious pieces designed to answer multiple requirements.

It offers options of great practicability to create welfare, balanced and well solved atmospheres.

HERA est conçu pour profiter de votre espace salle de bain.

Des éléments beaucoup plus grands et spacieux, conçus pour répondre à de multiples besoins. Ils offrent de grandes possibilités de créer des atmosphères de bien-être et d'équilibre.



Grupo B
Bernini

Grupo C
Bennu 07

Hera

MUEBLE
UNIT
MEUBLE

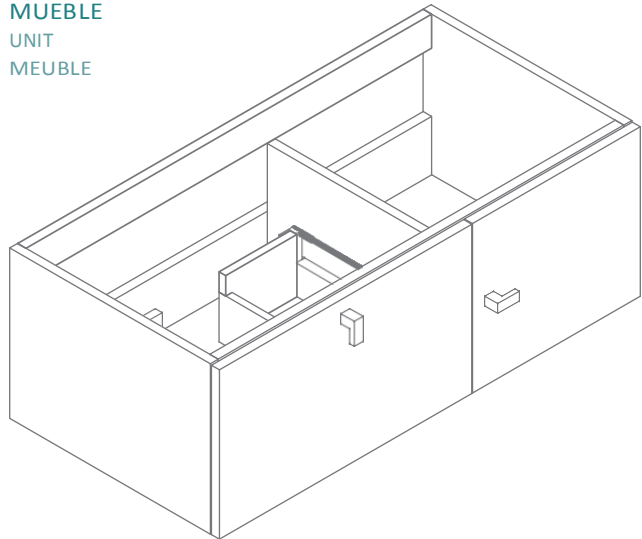

ALZADO IZQUIERDO
LEFT LAY OUT
PLAN PROFIL GAUCHE

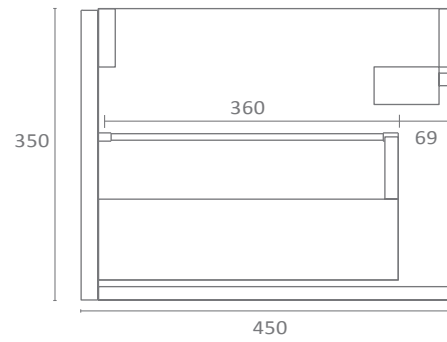

ALZADO DERECHO
RIGHT LAY OUT
PLAN PROFIL DROIT

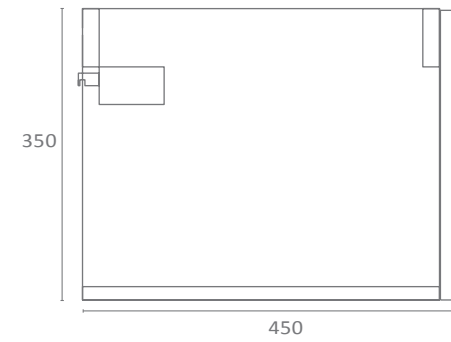

FRONTAL 1 CONTENEDOR 1 PUERTA
FRONT SIDE 1 BIG DRAWER 1 DOOR
FAÇADE AVEC 1 TIROIR 1 PORTE

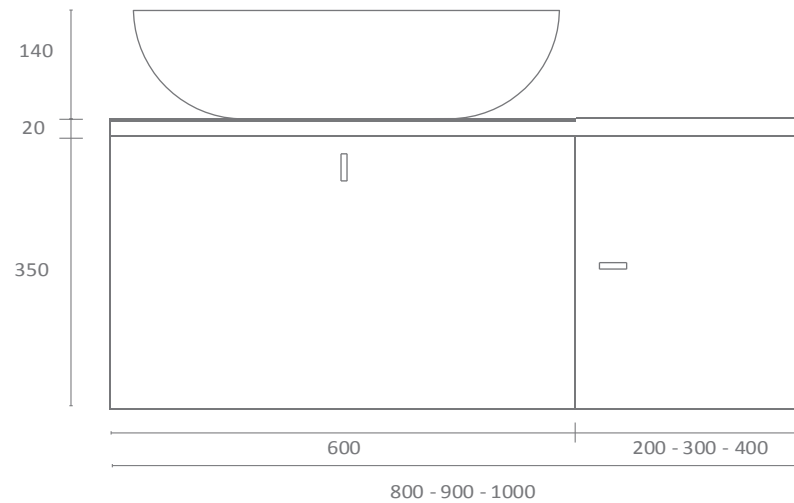

DESCRIPCIÓN DESCRIPTION DESCRIPTION	CARACTERÍSTICAS CHARACTERISTICS CARACTÉRISTIQUES			MEDIDAS (Ancho x Alto x Fondo) MEASUREMENTS (Width x Height x Depth) DIMENSIONS (Largeur x Hauteur x Profondeur)	GRUPO GROUP GROUPE A	GRUPO GROUP GROUPE B	GRUPO GROUP GROUPE C	LACA	LACA
								Mate y Texturado MATT LACQUER	Brillo y Engomado GLOSSY LACQUER
								(and Textured)	(and Rubber finish)
								LAQUE Mate et avec texture	LAQUE Brillant et effet gomme
Hera	Mueble suspendido con contenedor y 1 puerta	Contenedor Big Drawer Tiroir	Puerta Door Porte	800 x 350 x 450 mm					
	Wall Unit with big drawer and 1 door	600	200	900 x 350 x 450 mm					
	Meuble suspendu avec tiroir et une porte	600	300	1000 x 350 x 450 mm					
				805 x 460					
		Tapa Top Plateau meuble		905 x 460					
				1005 x 460					
	Calado tapa para lavabo Basin cut in the top Découpe vasque sur plateau								
Lavabo Nettuno 550 Nettuno Basin Vasque Nettuno	Lavabo cerámico sobreencimera Over countertop ceramic basin Vasque céramique sur plan de travail			550 x 140 x 405 mm					

* Especificar al realizar el pedido la configuración del mueble; si es Contenedor IZquierdo y Puerta Derecha ó Puerta Izquierda y Contenedor Derecho.

* Specify the configuration of the unit in the order, either it goes with the big drawer on the left and door on the right side, or vice versa.

* Préciser à la commande la configuration du meuble: Tiroir à gauche et porte à droite ou porte à gauche et tiroir à droite.

Mimosa

Grupo LPA
Roble Poro LPA Verdoso



La serie MIMOSA, elaborada en madera de roble lacado a poro abierto evoca otros tiempos desde el presente. Los muebles auxiliares otorgan personalidad con un diseño retro que imprime además calidez a tu baño.

MIMOSA, made in oak wood with open pore lacquered process, it evokes the past from the present. The auxiliary units grants personality with a retro design which brings warmth to your bath.

La série MIMOSA, conçue en bois de chêne laqué à pore ouvert, évoque le passé. Les meubles auxiliaires donnent à votre salle de bain de la personnalité, avec un design rétro, elle la rend plus chaleureuse.



Mimosa

MUEBLE
UNIT
MEUBLE

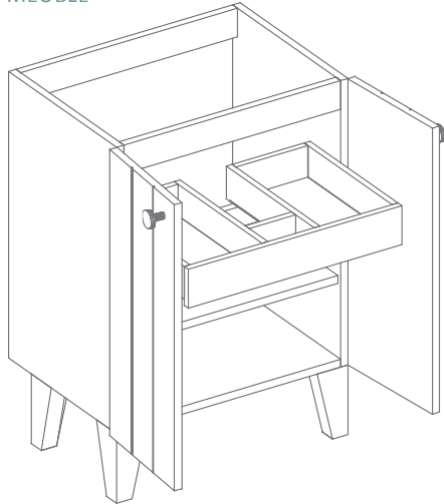

FRONTAL
FRONT SIDE
FAÇADE

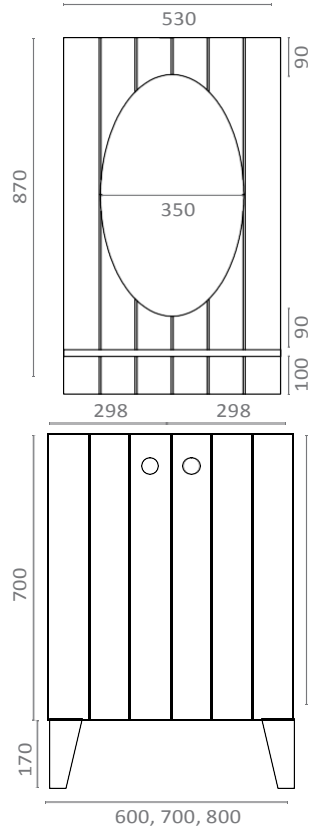

ALZADO DERECHO
RIGHT LAY OUT
PLAN PROFIL DROIT

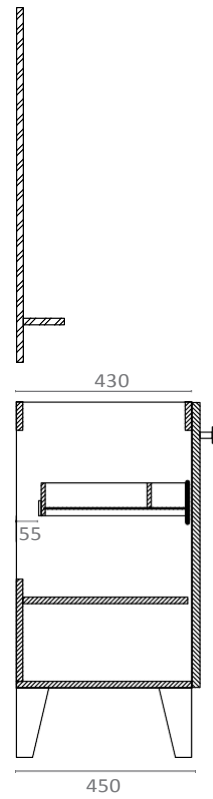

FRONTAL
FRONT SIDE
FAÇADE

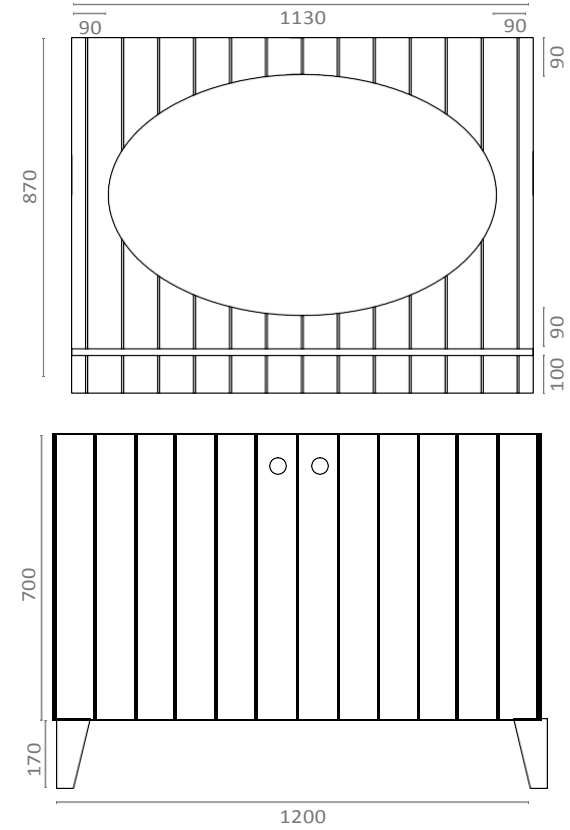

MUEBLE TOALLERO
TOWEL RACK UNIT
MEUBLEPORTE-SERVIETTE

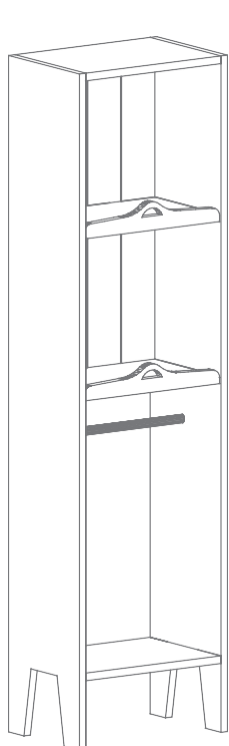

FRONTAL
FRONT SIDE
FAÇADE

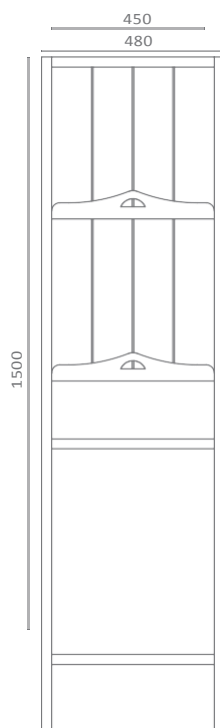

ALZADO DERECHO
RIGHT LAY OUT
PLAN PROFIL DROIT

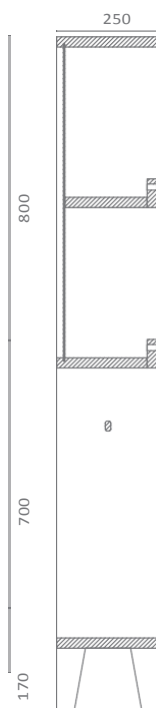

COLUMNA 1 PUERTA Y 2 CAJONES
1 DOOR AND 2 BIG DRAWERS COLUMN
COLONNE 1 PORTE ET 2 TIROIRS

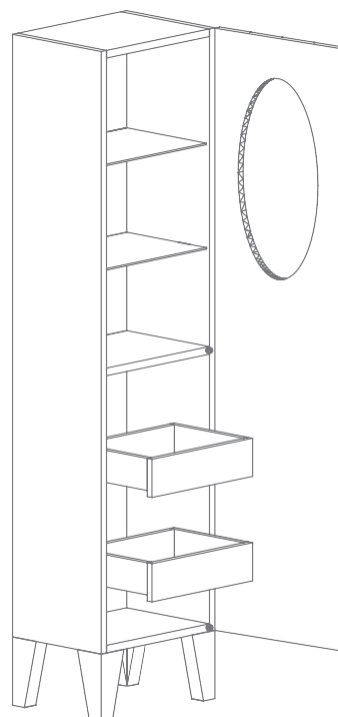

FRONTAL
FRONT SIDE
FAÇADE

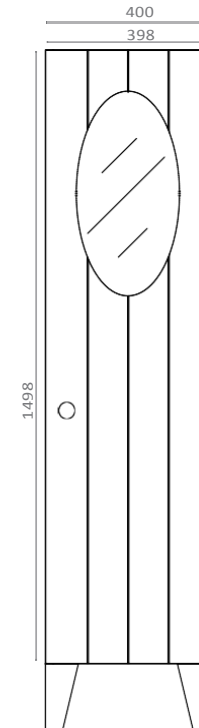

ALZADO DERECHO
RIGHT LAY OUT
PLAN PROFIL DROIT

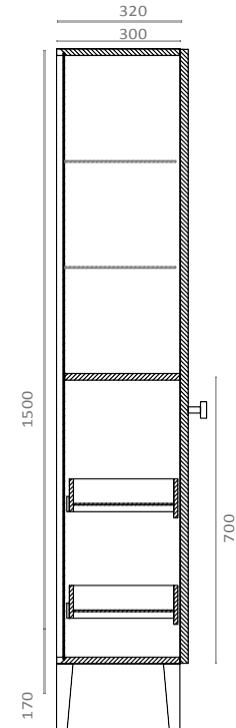

DESCRIPCIÓN DESCRIPTION DESCRIPTION	CARACTERÍSTICAS CHARACTERISTICS CARACTÉRISTIQUES	MEDIDAS (Ancho x Alto x Fondo) MEASUREMENTS (Width x Height x Depth) DIMENSIONS (Largeur x Hauteur x Profondeur)	LPA
Mueble Unit Meuble	Mueble con 1 Puerta One door Une porte	1P 600 y 1 cajón de madera con salva sifón 1D 600 / 1 Wooden drawer with trap protection 1 Porte 600 / 1 tiroir en bois avec découpe pour siphon	600 x 700 x 450 mm
	Mueble con 2 Puertas Two doors Deux portes	2P 300 y 1 cajón de madera con salva sifón 2D 300 / 1 Wooden drawer with trap protection 2 Portes 300 / 1 tiroir en bois avec découpe pour siphon	600 x 700 x 450 mm
		2P 350 y 1 cajón de madera con salva sifón 2D 350 / 1 Wooden drawer with trap protection 2 Portes 350 / 1 tiroir en bois avec découpe pour siphon	700 x 700 x 450 mm
		2P 400 y 1 cajón de madera con salva sifón 2D 400 / 1 Wooden drawer with trap protection 2 Portes 400 / 1 tiroir en bois avec découpe pour siphon	800 x 700 x 450 mm
		2P 600 y 1 cajón de madera con salva sifón 2D 600 / 1 Wooden drawer with trap protection 2 Portes 600 / 1 tiroir en bois avec découpe pour siphon	1200 x 700 x 450 mm
Marco con Espejo Óvalo + Repisa Frame with Oval Mirror + Shelf Cadre avec miroir oval + Tablette	para mueble de 600 for 600 unit pour meuble de 600	530 x 870 mm	
	para mueble de 700 for 700 unit pour meuble de 700	630 x 870 mm	
	para mueble de 800 for 800 unit pour meuble de 800	730 x 870 mm	
	para mueble de 1200 for 1200 unit pour meuble de 1200	1130 x 870 mm	
Mueble Toallero Towel rack Unit Meuble porte-serviettes	Toallero con 2 baldas decorativas 2 shelves and towel rod 2 étagères et porte-serviettes	480 x 1670 x 250 mm	
Columna con Puerta Vitrina Ovalada y 2 Cajones Column with Oval Frame Door and 2 drawers Colonne avec porte vitrine ovale et 2 tiroirs	1P vitrina ovalada, 2 cajones de madera y 2 baldas cristal 1 Upper Door / 2 Wooden drawers / 2 Glass shelves 1 Porte haute / 2 tiroirs en bois / 2 étagères en verre	400 x 1670 x 320 mm	



Ligne
Collection
Línea

ESTILO

Diseño depurado.
Funcionalidad y calidez.

Refined Design.
Functionality and warmth.

Design épuré.
Modèle fonctionnel et chaleureux.

Beatriz

Cómoda y funcional.

Comfortable and functional.

Confortable et pratique.





Grupo B
Metzia 071

Beatriz

MUEBLE
UNIT
MEUBLE



FRONTAL
FRONT SIDE
FAÇADE

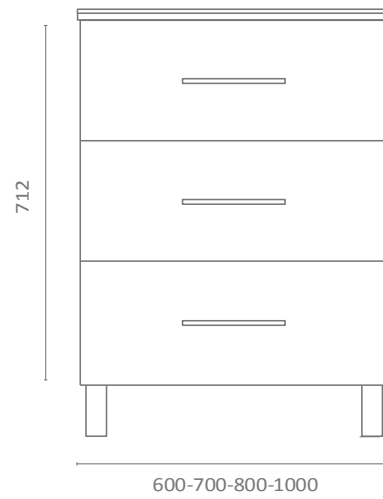

ALZADO DERECHO
RIGHT LAY OUT
PLAN PROFIL DROIT

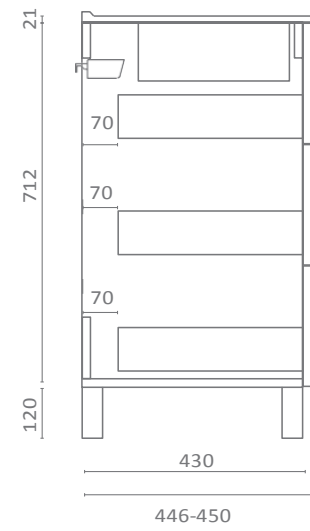

DESCRIPCIÓN DESCRIPTION DESCRIPTION	CARACTERÍSTICAS CHARACTERISTICS CARACTÉRISTIQUES	MEDIDAS (Ancho x Alto x Fondo) MEASUREMENTS (Width x Height x Depth) DIMENSIONS (Largeur x Hauteur x Profondeur)	GRUPO GROUP GROUPE A	GRUPO GROUP GROUPE B	GRUPO GROUP GROUPE C
Beatriz	Mueble con patas y 3 cajones Unit with legs and 3 drawers Meuble avec pieds et 3 tiroirs	600 x 712 x 450			
		700 x 712 x 450			
		800 x 712 x 450			
		900 x 712 x 450			
		1000 x 712 x 450			
		1200 x 712 x 450			
	Mueble con patas y 3 cajones doble seno Unit with legs and 3 drawers double bowls Meuble avec pieds, 3 tiroirs et double vasque	1200 x 712 x 450			

Bianca

Armonía y paz en tu baño.

Harmony and peace in your bath.

Harmonie et paix dans votre salle de bain.





Grupo A
Mercurio 20

Bianca

BIANCA LINEAL

MUEBLE
UNIT
MEUBLE

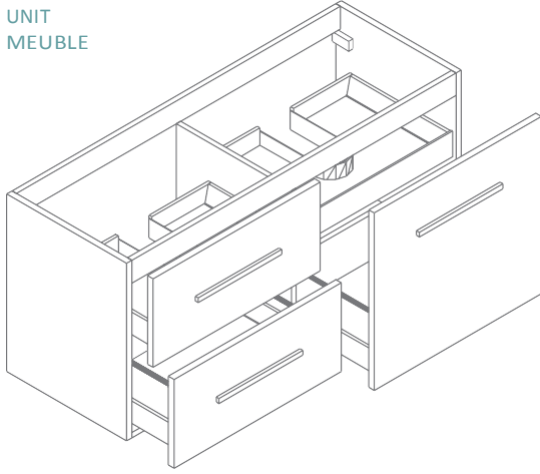

ALZADO IZQUIERDO
LEFT LAY OUT
PLAN PROFIL GAUCHE

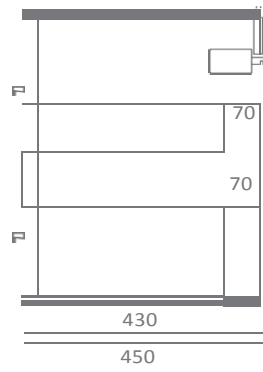

FRONTAL
FRONT SIDE
FAÇADE

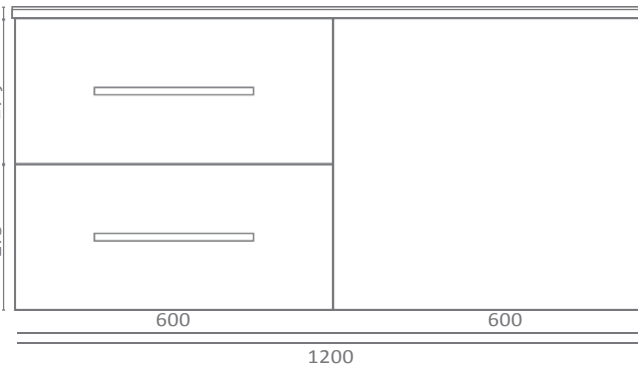

ALZADO DERECHO
RIGHT LAY OUT
PLAN PROFIL DROIT

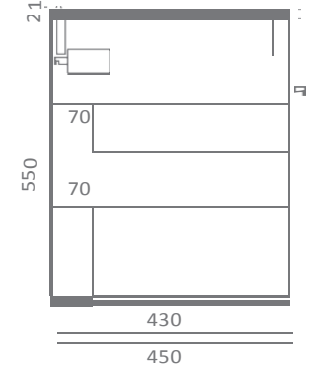

BIANCA

MUEBLE
UNIT
MEUBLE

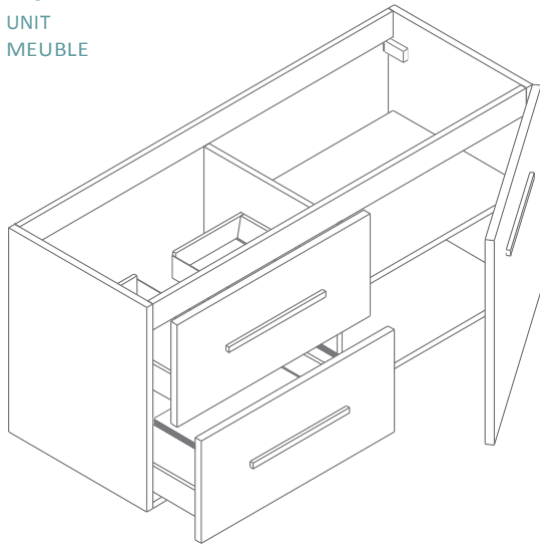

ALZADO IZQUIERDO
LEFT LAY OUT
PLAN PROFIL GAUCHE

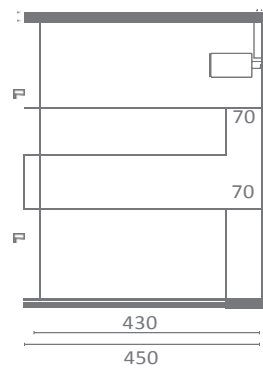

FRONTAL
FRONT SIDE
FAÇADE

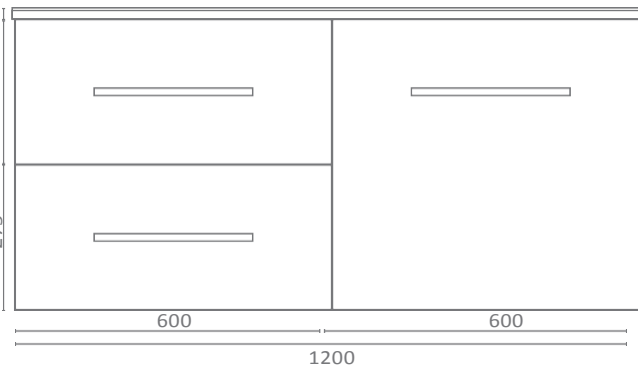

ALZADO DERECHO
RIGHT LAY OUT
PLAN PROFIL DROIT

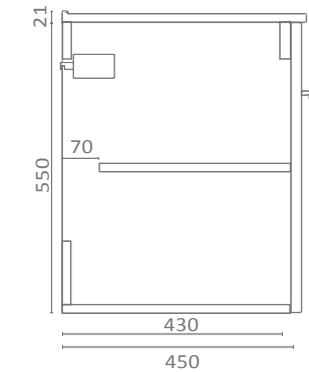

BIANCA TOTAL

MUEBLE
UNIT
MEUBLE

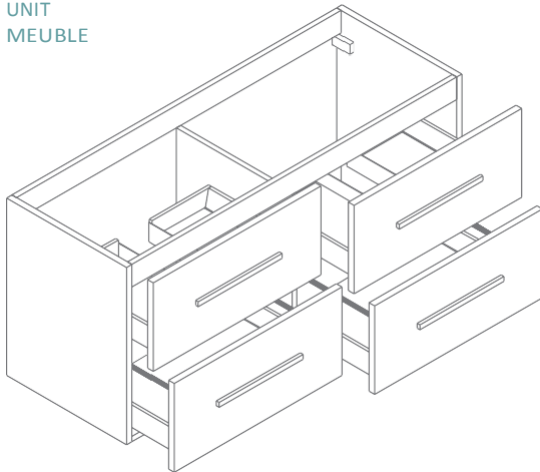

FRONTAL
FRONT SIDE
FAÇADE

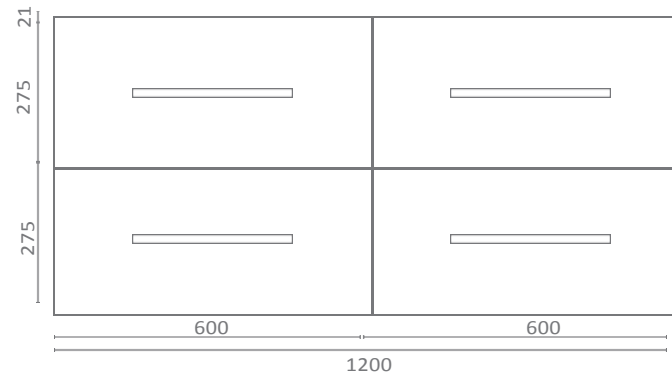

ALZADO DERECHO
RIGHT LAY OUT
PLAN PROFIL DROIT

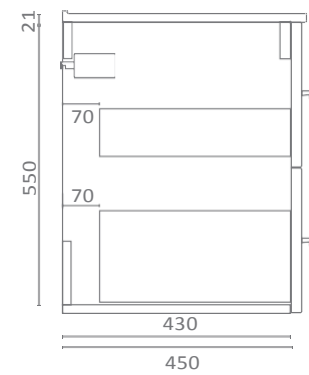

DESCRIPCIÓN DESCRIPTION DESCRIPTION	CARACTERÍSTICAS CHARACTERISTICS CARACTÉRISTIQUES	MEDIDAS (Ancho x Alto x Fondo) MEASUREMENTS (Width x Height x Depth) DIMENSIONS (Largeur x Hauteur x Profondeur)	GRUPO GROUP GROUPE A	GRUPO GROUP GROUPE B	GRUPO GROUP GROUPE C
Bianca Lineal *	Mueble suspendido con 1 cajón, 1 contenedor + 1 puerta con cajón y contenedor interiores Hanged Unit with 1 drawer, 1 big drawer + 1 door with drawer and interior big drawers Meuble suspendu avec 2 tiroirs + 1 coulissant avec tiroir à l'anglaise	1200 x 550 x 450			
Bianca *	Mueble suspendido con 1 cajón, 1 contenedor + 1 puerta con balda Hanged unit with 1 drawer, 1 Big drawer + 1 Door with shelf Meuble suspendu avec 2 tiroirs + 1 porte et étagère	1200 x 550 x 450			
Bianca Total	Mueble suspendido con 4 contenedores Hanged unit with 4 big drawers Meuble suspendu avec 4 tiroirs	1200 x 550 x 450			

* Especificar al realizar el pedido la configuración del mueble; si la puerta queda a la derecha o a la izquierda.

* Specify the configuration of the unit, either the door goes on the right or left side.

* Préciser à la commande la configuration du meuble; porte à droite ou à gauche.

Carla



Grupo B
Metzia 71 (Frentes / Doors / Façades)
Seissa 1102 (Costados / Side panels / Côtés)



 Grupo B
Meidass 40 (Frentes / Doors / Façades)
Arena 04 (Costados / Side panels / Côtés)

Carla

MUEBLE
UNIT
MEUBLE

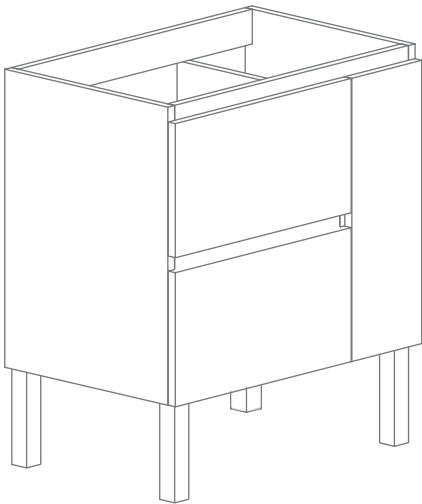
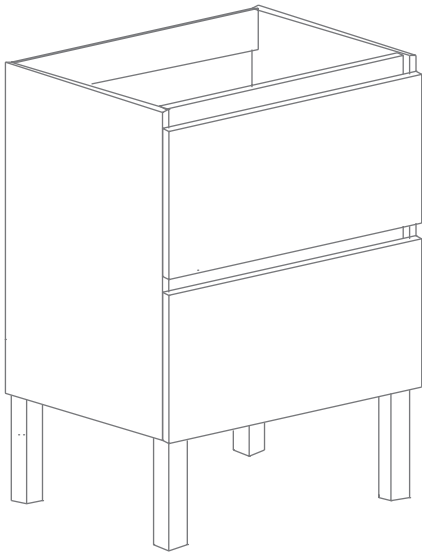

FRONTAL
FRONT SIDE
FAÇADE

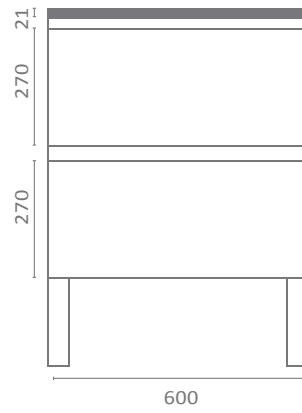

ALZADO DERECHO
RIGHT LAY OUT
PLAN PROFIL DROIT

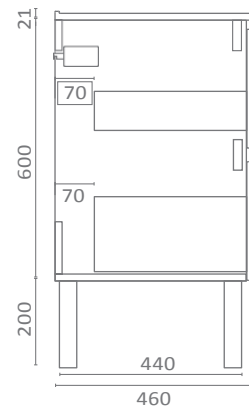

ALZADO IZQUIERDO
LEFT LAY OUT
PLAN PROFIL GAUCHE

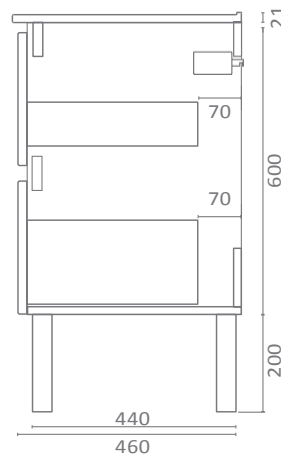

FRONTAL
FRONT SIDE
FAÇADE

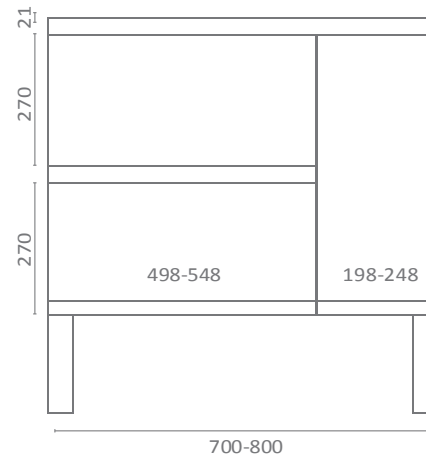

ALZADO DERECHO
RIGHT LAY OUT
PLAN PROFIL DROIT

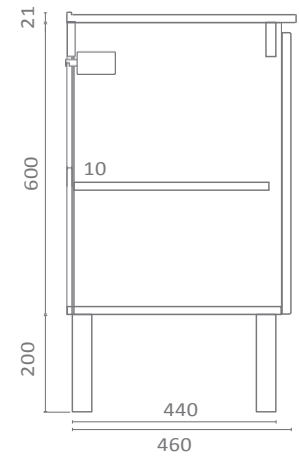

DESCRIPCIÓN DESCRIPTION DESCRIPTION	CARACTERÍSTICAS CHARACTERISTICS CARACTÉRISTIQUES	MEDIDAS (Ancho x Alto x Fondo) MEASUREMENTS (Width x Height x Depth) DIMENSIONS (Largeur x Hauteur x Profondeur)	GRUPO GROUP GROUPE	GRUPO GROUP GROUPE	GRUPO GROUP GROUPE
			A	B	C
	Mueble con patas con 1 cajón y 1 contenedor Unit with legs with 1 drawer and 1 big drawer Meuble sur pieds avec 2 tiroirs	600 x 600 x 460			
Carla *	Mueble con patas con 1 cajón, 1 contenedor y 1 puerta Unit with legs with 1 drawer, 1 big drawer and 1 door Meuble sur pieds, avec 2 tiroirs et 1 porte	700 x 600 x 460			
		800 x 600 x 460			

* Especificar al realizar el pedido la configuración del mueble; si la puerta queda a la derecha o a la izquierda.

* Specify the configuration of the unit, either the door goes on the right or left side.

* Préciser à la commande la configuration du meuble; porte à droite ou à gauche.

Davo



Grupo B
Meidass 41 (Frentes / Doors / Façades)
Meidass 43 (Costados / Side panels / Côtés)



Grupo A
Cuero 01

Davo

DAVO

MUEBLE
UNIT
MEUBLE

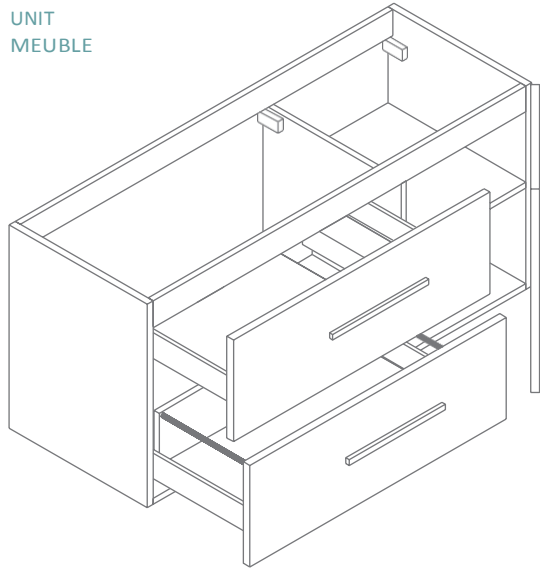

ALZADO IZQUIERDO
LEFT LAY OUT
PLAN PROFIL GAUCHE

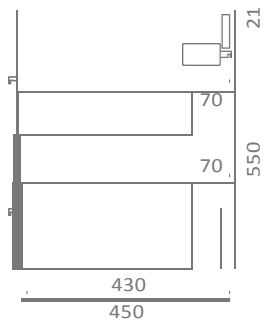

FRONTAL
FRONT SIDE
FAÇADE

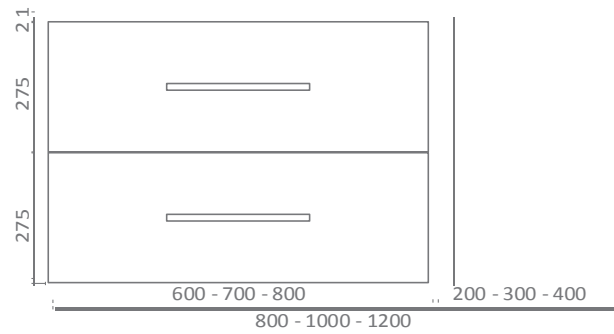

ALZADO DERECHO
RIGHT LAY OUT
PLAN PROFIL DROIT

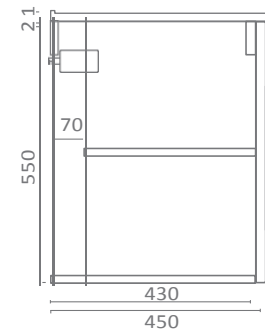

DAVO LINEAL

MUEBLE
UNIT
MEUBLE

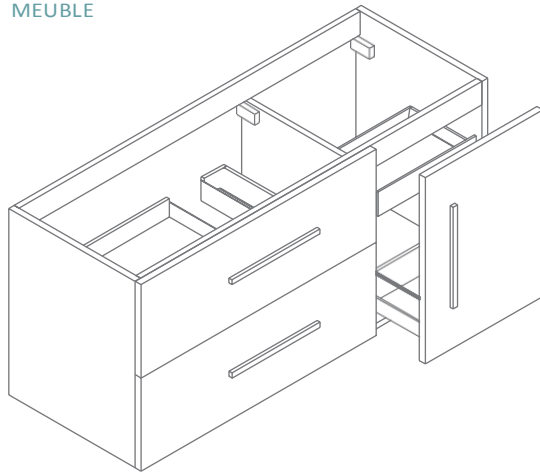

ALZADO IZQUIERDO
LEFT LAY OUT
PLAN PROFIL GAUCHE

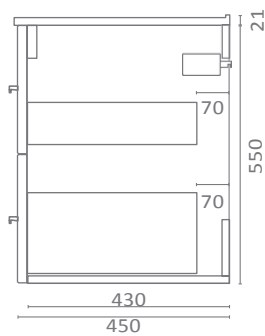

FRONTAL
FRONT SIDE
FAÇADE

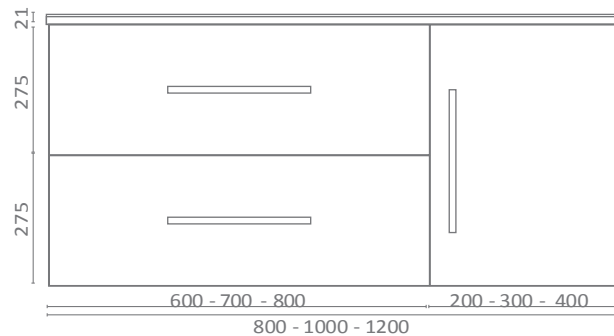

ALZADO DERECHO
RIGHT LAY OUT
PLAN PROFIL DROIT

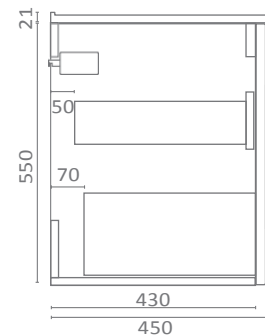

DAVO TOTAL

MUEBLE
UNIT
MEUBLE

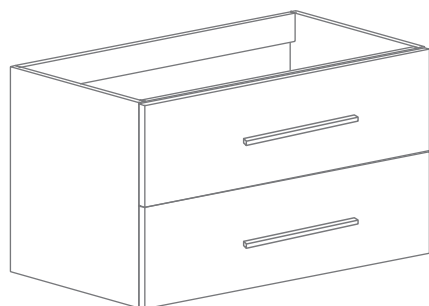

ALZADO IZQUIERDO
LEFT LAY OUT
PLAN PROFIL GAUCHE

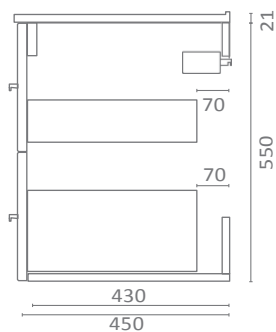

FRONTAL
FRONT SIDE
FAÇADE

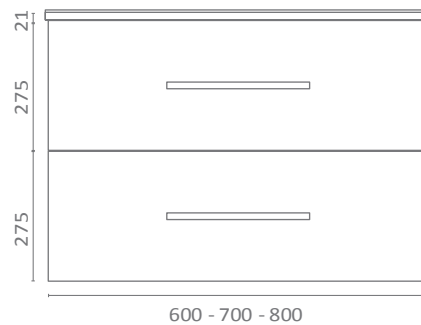

DESCRIPCIÓN DESCRIPTION DESCRIPTION	CARACTERÍSTICAS CHARACTERISTICS CARACTÉRISTIQUES	MEDIDAS (Ancho x Alto x Fondo) MEASUREMENTS (Width x Height x Depth) DIMENSIONS (Largeur x Hauteur x Profondeur)	GRUPO GROUP GROUPE	GRUPO GROUP GROUPE	GRUPO GROUP GROUPE
			A	B	C
Davo *	Mueble suspendido con 1 cajón, 1 contenedor y 1 puerta con balda Wall unit with 1 drawer, 1 big drawer and 1 door with shelf * Meuble suspendu avec 2 tiroirs et 1 porte avec étagère *	800 x 550 x 450			
		1000 x 550 x 450			
		1200 x 550 x 450			
Davo Lineal *	Mueble suspendido con 1 cajón, 1 contenedor y 1 puerta con cajón y contenedor interiores Wall unit with 1 drawer, 1 big drawer and 1 door with drawer and interior big drawers* Meuble suspendu avec 2 tiroirs et 1 coulissant avec tiroir à l'anglaise *	800 x 550 x 450			
		1000 x 550 x 450			
		1200 x 550 x 450			
Davo Total	Mueble suspendido con 1 cajón y 1 contenedor Wall Unit with 1 drawer and 1 big drawer Meuble suspendu avec 2 tiroirs	600 x 550 x 450			
		700 x 550 x 450			
		800 x 550 x 450			

* Especificar al realizar el pedido la configuración del mueble; si la puerta queda a la derecha o a la izquierda.

* Specify the configuration of the unit, either the door goes on the right or left side.

* Préciser à la commande la configuration du meuble; porte à droite ou à gauche.

On

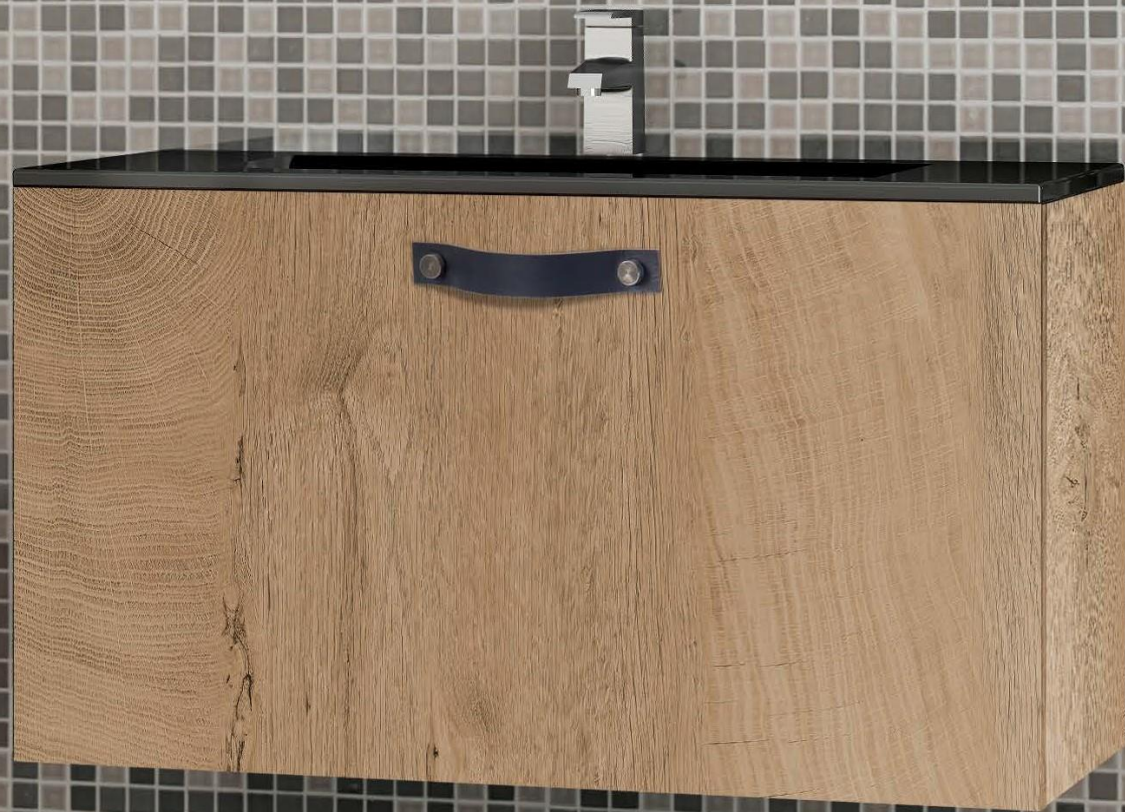

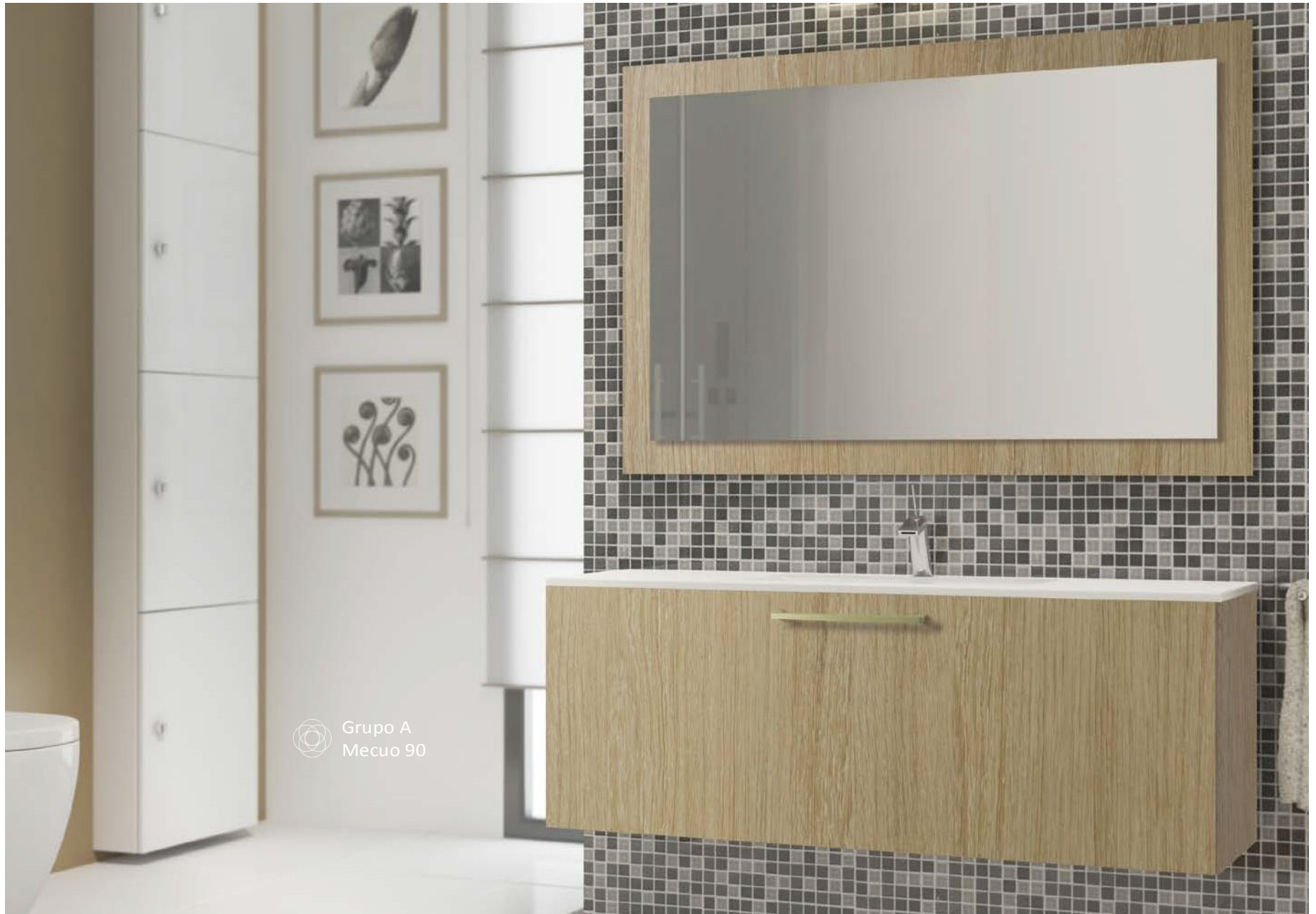

 Grupo A
Mecuo 90

On

MUEBLE
UNIT
MEUBLE

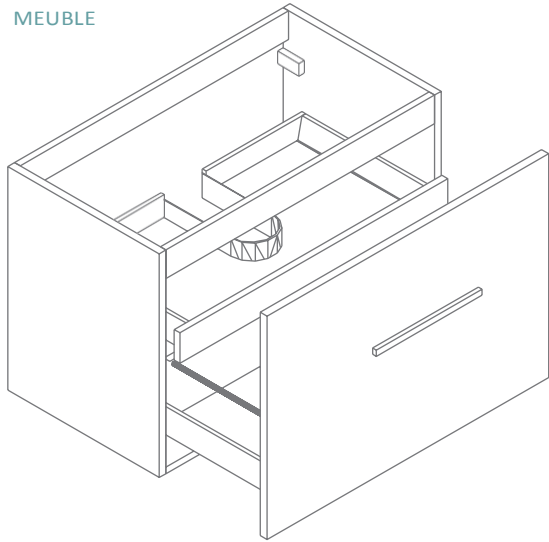

FRONTAL
FRONT SIDE
FAÇADE

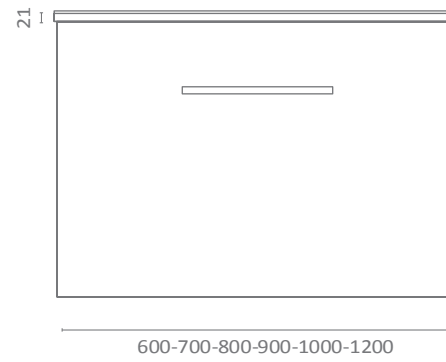

ALZADO DERECHO
RIGHT LAY OUT
PLAN PROFIL DROIT

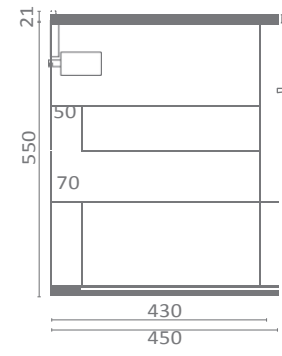

DESCRIPCIÓN DESCRIPTION DESCRIPTION	CARACTERÍSTICAS CHARACTERISTICS CARACTERISTIQUES	MEDIDAS (Ancho x Alto x Fondo) MEASUREMENTS (Width x Height x Depth) DIMENSIONS (Largeur x Hauteur x Profondeur)	GRUPO GROUP GROUPE	GRUPO GROUP GROUPE	GRUPO GROUP GROUPE
			A	B	C
		600 x 550 x 450			
		700 x 550 x 450			
	Mueble suspendido con 1 contenedor y 1 cajón interior	800 x 550 x 450			
	Wall unit with 1 big drawer and 1 interior drawer				
	Meuble suspendu avec 1 tiroir et 1 tiroir à l'anglaise	900 x 550 x 450			
		1000 x 550 x 450			
On		1200 x 550 x 450			
	Mueble suspendido con 1 contenedor y 1 cajón interior doble seno				
	Wall unit with 1 big drawer and 1 interior drawer. Double Bowl	1200 x 550 x 450			
	Meuble suspendu avec 1 tiroir et 1 tiroir à l'anglaise vasque double				

Tao

TAO



TAO
con T22





TAO
GOLA



Grupo A
Mercurio 008

Tao

TAO

MUEBLE
UNIT
MEUBLE

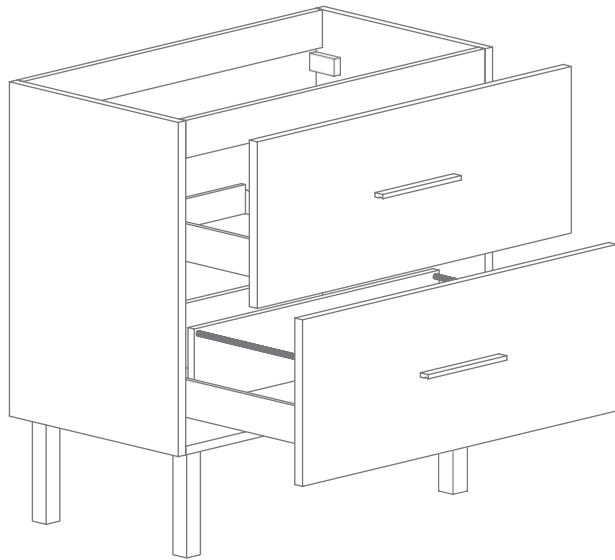

FRONTAL
FRONT SIDE
FAÇADE

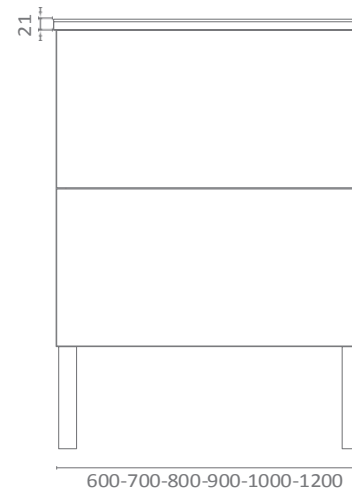

ALZADO DERECHO
RIGHT LAY OUT
PLAN PROFIL DROIT

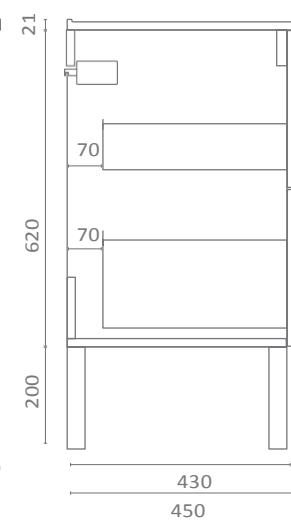

TAO GOLA

MUEBLE
UNIT
MEUBLE

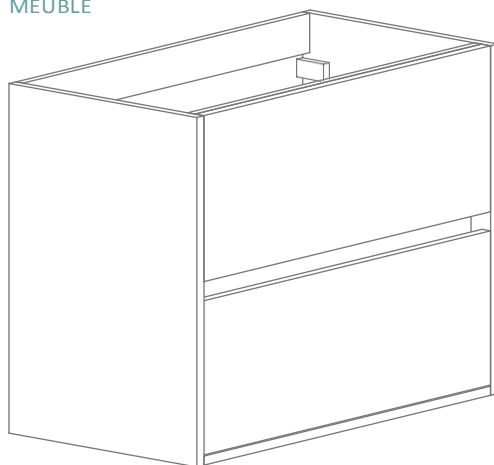

FRONTAL
FRONT SIDE
FAÇADE

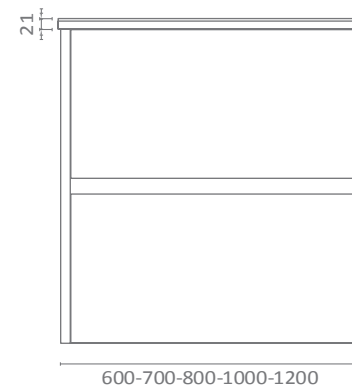

ALZADO DERECHO
RIGHT LAY OUT
PLAN PROFIL DROIT

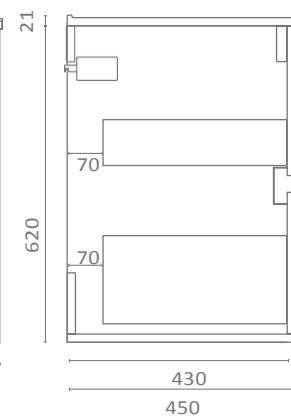

DESCRIPCIÓN DESCRIPTION DESCRIPTION	CARACTERÍSTICAS CHARACTERISTICS CARACTERISTIQUES	MEDIDAS (Ancho x Alto x Fondo) MEASUREMENTS (Width x Height x Depth) DIMENSIONS (Largeur x Hauteur x Profondeur)	GRUPO GROUP GROUPE A	GRUPO GROUP GROUPE B	GRUPO GROUP GROUPE C	
Tao	Mueble con patas con 1 cajón y 1 contenedor tirador estándar Unit with legs with 1 drawer and 1 big drawer. Standard Handle Meuble sur pieds avec 2 tiroirs poignée standard	600 x 620 x 450				
		700 x 620 x 450				
		800 x 620 x 450				
		900 x 620 x 450				
		1000 x 620 x 450				
		1200 x 620 x 450				
Tao Gola	Mueble con patas con 1 cajón y 1 contenedor tirador estándar doble seno Unit with legs with 1 drawer and 1 big drawer. Standard Handle. Double Bowl Meuble sur pieds avec 2 tiroirs, poignée standard, double vasque	1200 x 620 x 450				
		Mueble suspendido con 1 cajón y 1 contenedor Gola Gola wall unit with 1 drawer and 1 big drawer Meuble sur pieds avec 2 tiroirs système de gorge	600 x 620 x 450			
			700 x 620 x 450			
			800 x 620 x 450			
			900 x 620 x 450			
			1000 x 620 x 450			
1200 x 620 x 450						
Tao Gola	Mueble suspendido con 1 cajón y 1 contenedor Gola doble seno Gola wall unit with 1 drawer and 1 big drawer. Double bowl Meuble suspendu avec 2 tiroirs système de gorge et vasque double	1200 x 620 x 450				



AUXILIARES

Auxiliary Units
Meubles Auxiliaires

Columna

COLUMNA CAJÓN
COLUMN DRAWER UNIT
COLONNE TIROIR



FRONTAL
FRONT SIDE
FAÇADE

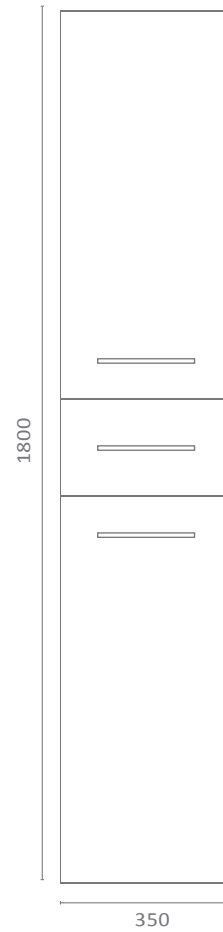

ALZADO DERECHO
RIGHT LAY OUT
PLAN PROFIL DROIT

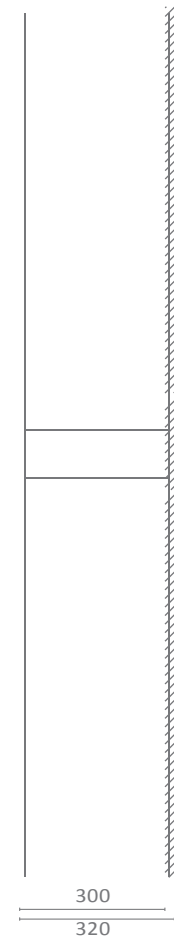

DESCRIPCIÓN DESCRIPTION DESCRIPTION	CARACTERÍSTICAS CHARACTERISTICS CARACTÉRISTIQUES	MEDIDAS (Ancho x Alto x Fondo) MEASUREMENTS (Width x Height x Depth) DIMENSIONS (Largeur x Hauteur x Profondeur)	GRUPO GROUP GROUPE A	GRUPO GROUP GROUPE B	GRUPO GROUP GROUPE C
Columna Cajón Column drawer Unit Colonne tiroir	Columna 350 2 puertas y cajón Column 350 2 doors and drawer Colonne de 350 avec 2 portes et 1 tiroir	350 x 1800 x 320			

Media Columna

MEDIA COLUMNA
SEMI COLUMN
DEMI COLONNE

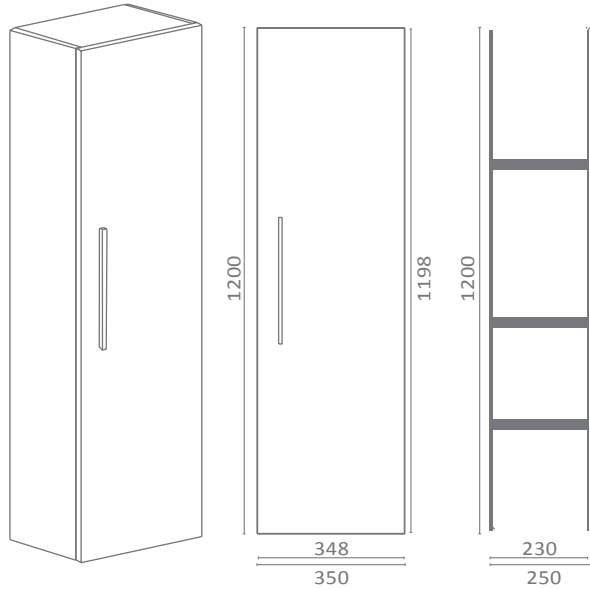

2 PUERTAS
2 DOORS
2 PORTES

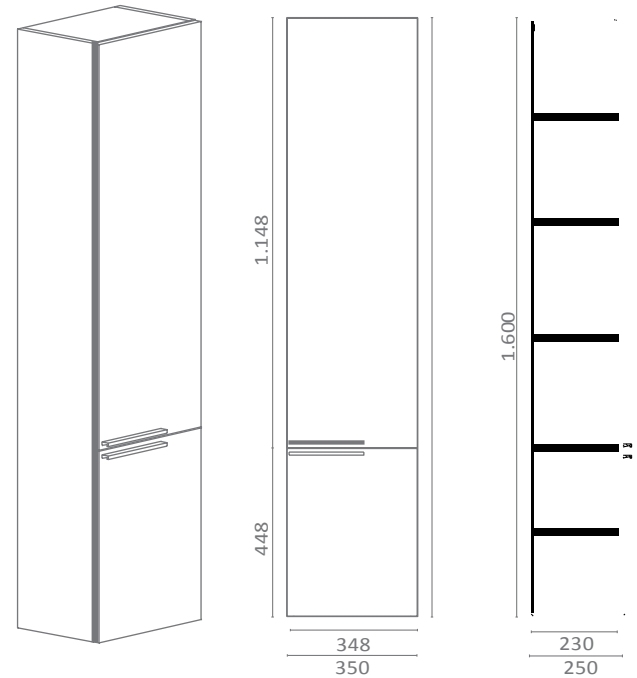

UÑERO
HANDLESS
PRISE DE MAIN

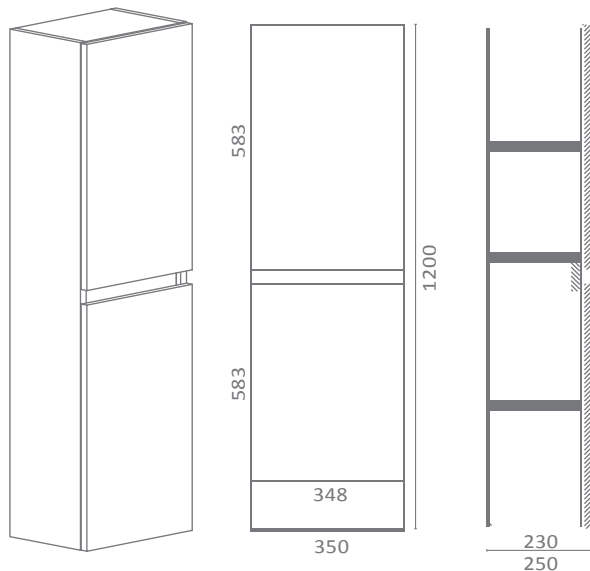

GOLA
GOLA
GORGE

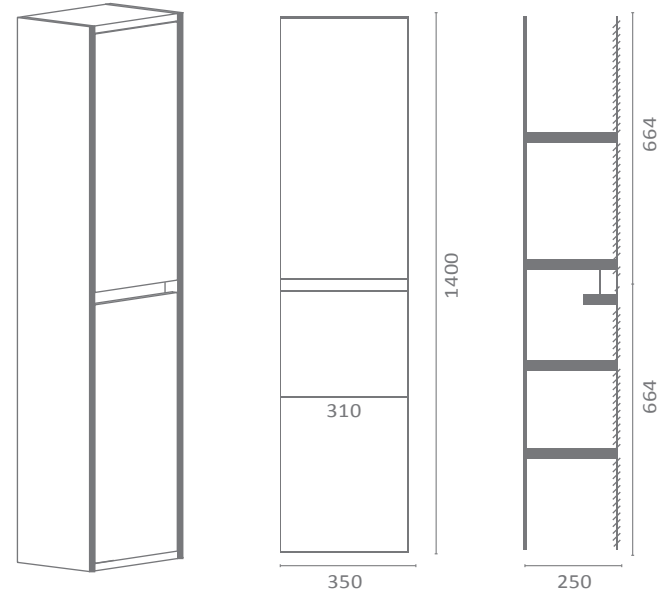

DESCRIPCIÓN DESCRIPTION DESCRIPTION	CARACTERÍSTICAS CHARACTERISTICS CARACTÉRISTIQUES	MEDIDAS (Ancho x Alto x Fondo) MEASUREMENTS (Width x Height x Depth) DIMENSIONS (Largeur x Hauteur x Profondeur)	GRUPO GROUP GROUPE A	GRUPO GROUP GROUPE B	GRUPO GROUP GROUPE C	LACA	
						LACA	
						MATE y Texturado (and Textured) LAQUE Mate et avec texture	Brillo y Engomado (and Rubber finish) LAQUE Brillant et effet gomme
Media Columna Semi Column Demi colonne	1P H.120 Suspending 1Door H.120 Hanged Meuble suspendu 1 porte H 1200	350 x 1200 x 250	24.562	29.814	33.315		
M C 2 puertas S C 2 doors D C 2 portes	1P Alta 1150 1P Baja 450 1 Upper Door 1150 1 Lower Door 450 1 porte haute de H 1150 et 1 porte basse de H 450	350 x 1600 x 250	34.375	42.316	43.989	51.672	62.951
	1P Alta 1150 1P Baja 450 1 Upper Door 1150 1 Lower Door 450 1 porte haute de H 1150 et 1 porte basse de H 450	400 x 1600 x 250	35.523	43.869	45.627	52.746	64.026
M C Uñero S C Handless D C prise de main	1P H.120 Suspending 1Door H.120 Hanged Meuble suspendu 1 porte H 1200	350 x 1200 x 250	24.562	29.814	33.315		
M C Gola S C Gola D M Gorge	Columna 350 2P Gola Suspending Column 350 2Doors Hanged Gola Colonne suspendue de 350 avec 2 portes Gola	350 x 1400 x 250	27.084	34.632	37.849		

Colgares

COLGAR CAJÓN
WALL DRAWER UNIT
ARMOIRETTE TIROIR

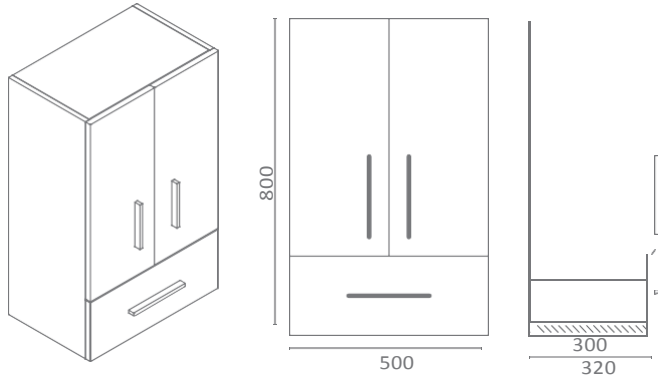

COLGAR UÑERO
WALL HANDLESS UNIT
ARMOIRETTE PRISE DE MAIN

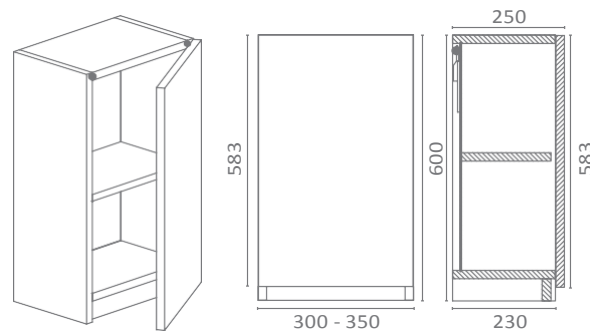

COLGAR UÑERO
WALL HANDLESS UNIT
ARMOIRETTE PRISE DE MAIN

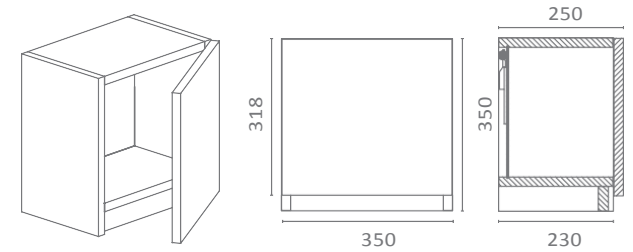

COLGAR
WALL UNIT
ARMOIRETTE

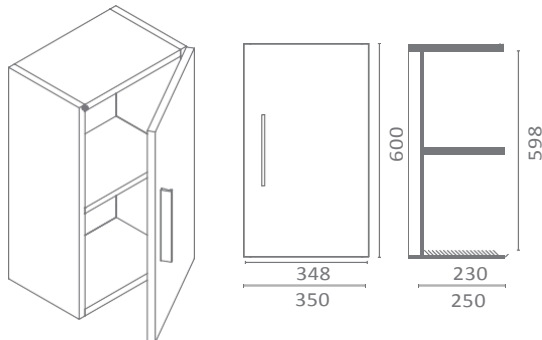

COLGAR
WALL UNIT
ARMOIRETTE

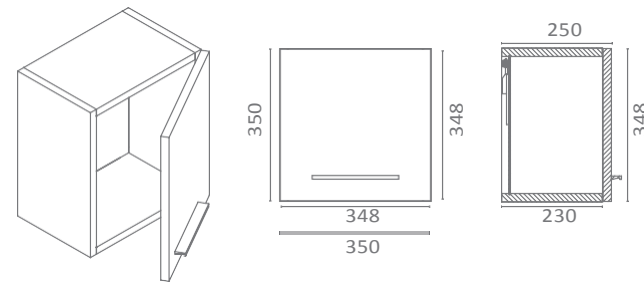

CAMERINO
MIRROR WALL UNIT
ARMOIRETTE MIROIR

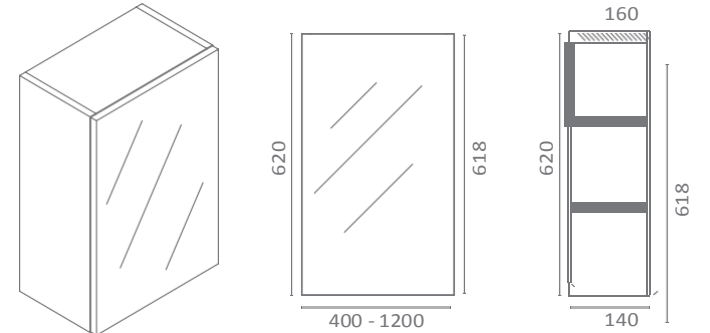

DESCRIPCIÓN DESCRIPTION DESCRIPTION	CARACTERÍSTICAS CHARACTERISTICS CARACTÉRISTIQUES	MEDIDAS (Ancho x Alto x Fondo) MEASUREMENTS (Width x Height x Depth) DIMENSIONS (Largeur x Hauteur x Profondeur)	GRUPO GROUP GROUPE A	GRUPO GROUP GROUPE B	GRUPO GROUP GROUPE C
Colgar Cajón Wall Drawer Unit Armoirette Tiroir	2 puertas y cajón 2 doors and drawer 2 portes et 1 tiroir	500 x 800 x 320			
Colgar Uñero Wall Handleless Unit Armoirette Prise De Main	1 Puerta / 1 Door / 1 Porte H 350 1 Puerta / 1 Door / 1 Porte H 600	350 x 350 x 250 350 x 600 x 250			
Colgar Wall Unit Armoirette	1 Puerta / 1 Door / 1 Porte H 350 1 Puerta / 1 Door / 1 Porte H 600 1 Puerta / 1 Door / 1 Porte H 600	350 x 350 x 250 300 x 600 x 250 350 x 600 x 250			
	1 Puerta / 1 Door / 1 Porte	400 x 620 x 160 500 x 620 x 160 600 x 620 x 160 700 x 620 x 160			
Camerino Mirror wall unit Armoirette Miroir	2 Puertas 2 Doors 2 Portes	800 x 620 x 160 900 x 620 x 160 1000 x 620 x 160 1200 x 620 x 160			

Decorativos

20 X 20

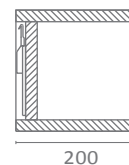
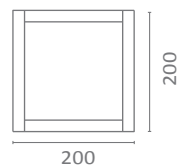
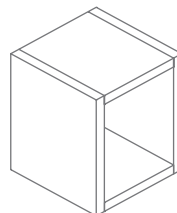

20 X 40

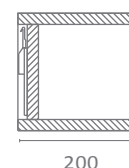
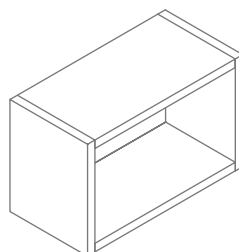

40 X 20

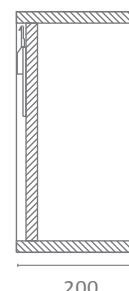
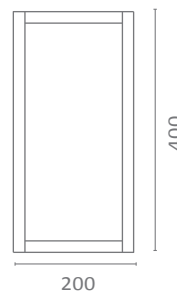
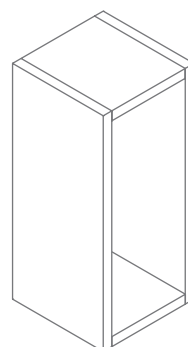

DESCRIPCIÓN DESCRIPTION DESCRIPTION	CARACTERÍSTICAS CHARACTERISTICS CARACTÉRISTIQUES	MEDIDAS (Ancho x Alto x Fondo) MEASUREMENTS (Width x Height x Depth) DIMENSIONS (Largeur x Hauteur x Profondeur)	GRUPO GROUP GROUPE A	GRUPO GROUP GROUPE B	GRUPO GROUP GROUPE C	LACA Mate y Texturado MATT LACQUER (and Textured) LAQUE Mate et avec texture	LACA Brillo y Engomado GLOSSY LACQUER (and Rubber finish) LAQUE Brillant et effet gomme
	Decorativo Decorative Meuble sans porte	200 x 200 x 200					
Decorativo Decorative Meuble s. porte	Decorativo rectángulo vertical Vertical rectangle decorative Meuble sans porte rectangulaire vertical	200 x 400 x 200					
	Decorativo rectángulo horizontal Horizontal rectangle decorative Meuble sans porte rectangulaire horizontal	400 x 200 x 200					



ACABADOS

Finishes
Finitions



Grupo A Laminados

Laminates Group

Groupe Méla/Strat

Mercurio



008



009



010



012



017



019



020

Madagascar



63



64



90



92



93

Petronas



81



82



83

Mecuo

Cuero



01



02



03

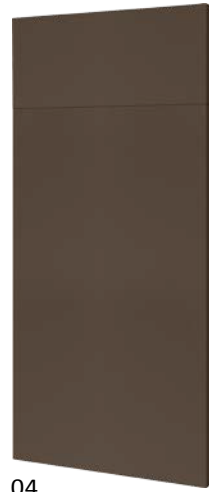

04

Arena



004

Bernini



Cemento



1



2



3

Seissa

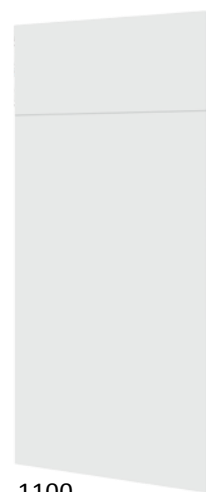

1100



1102

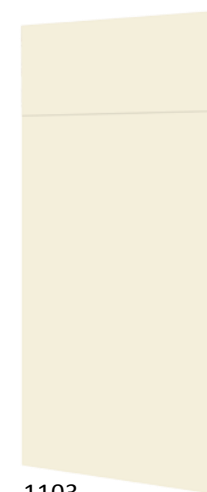

1103

Cuatro

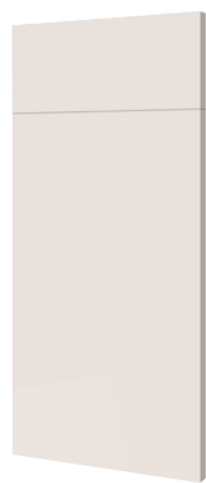

100



159



201



247



283



400



501

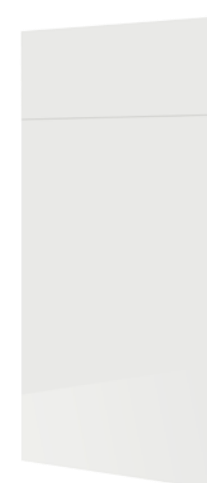

3091

Meidass



40



41



42



43

Metzia



71



73



Grupo C Laminados

Laminates Group
Groupe Méla/Strat

Glam

Bennu



05



01

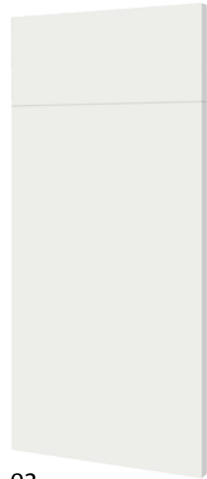

02



03



04



05

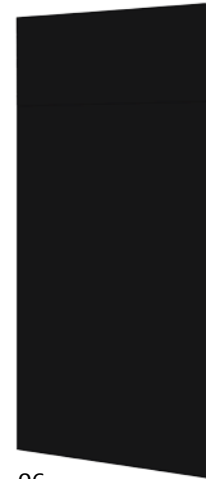

06



07



Grupo LPA (Mimosa)

LPA Wood (Mimosa) Group
Groupe Bois LPA (Mimosa)

Mimosa



Blanco



Gris



Negro



Piedra



Plata



Platino



Toffe



Verdoso



Nota: Todos los laminados están canteados a 4 cantos. El color de canto será siempre el del modelo, no existe la posibilidad de combinar cantos con modelos. No existe la posibilidad de combinar diferentes modelos dentro del mismo mueble.

Note: All laminates are 4 sided edge banded. The colour of the edge is always same as the model and it is not possible to combine colour of edges. It is not possible to combine different models in the same unit.

Remarque: Tous les stratifiés sont à chants plaqués. Le coloris du chant sera le même que celui du modèle. Il n'existe pas la possibilité de combiner les chants et les modèles. Il sera également impossible de combiner plusieurs modèles sur un seul meuble.



SERIGRAFÍAS

Screen Prints
Sérigraphies



 CUBO
SER - 03

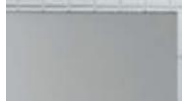

BIANCA TOTAL
SER-04

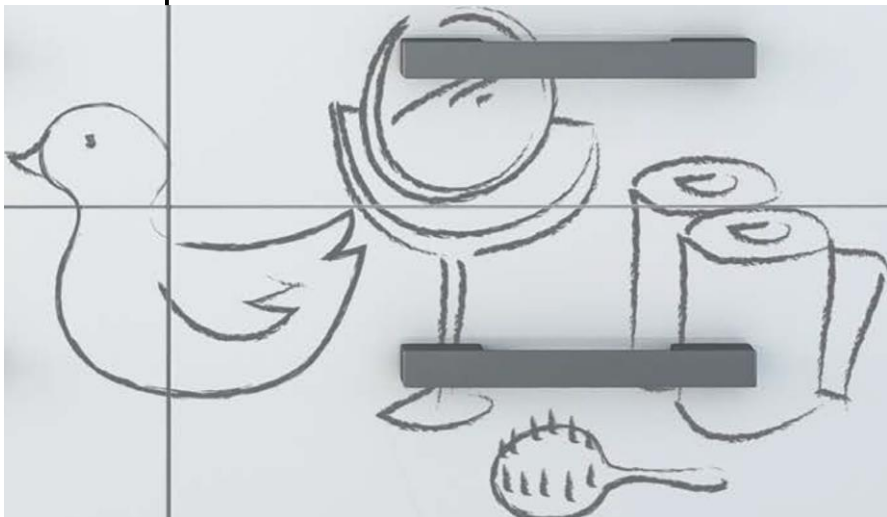
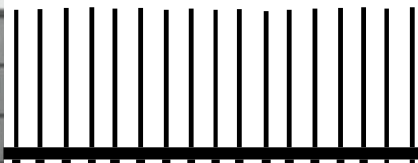

BIANCA
SER - 01

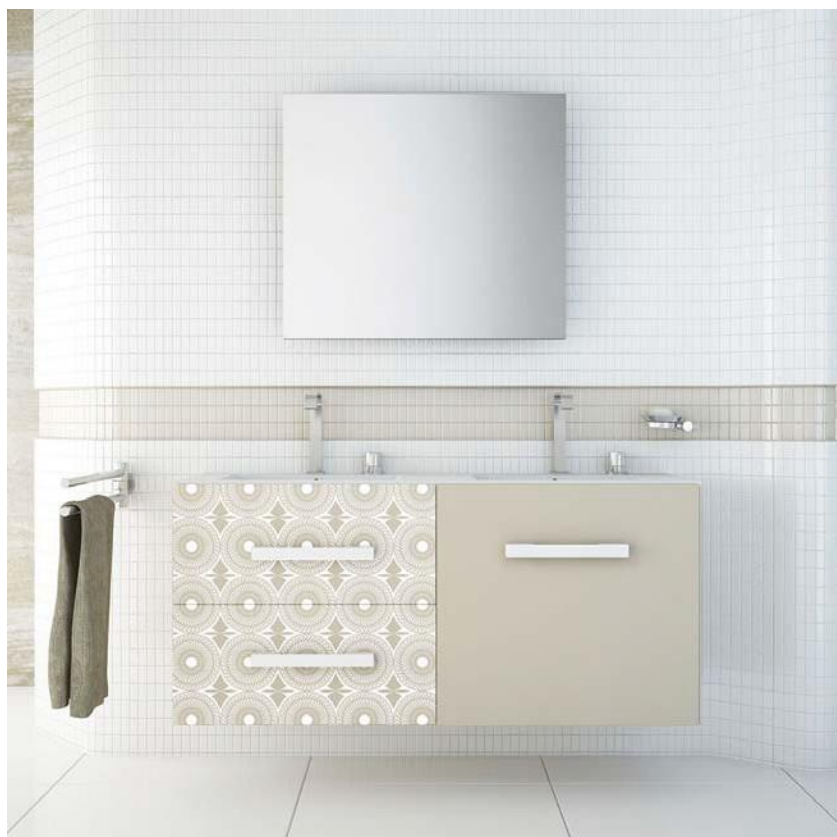

BIANCA LINEAL
SER - 01



BIANCA TOTAL
SER - 08

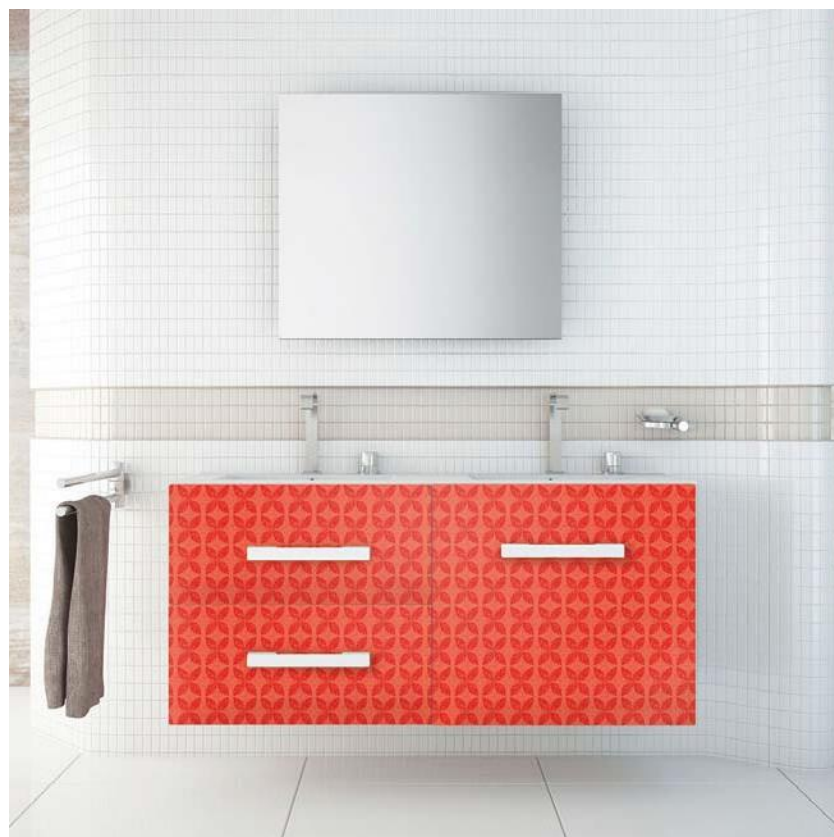

BIANCA
SER - 06

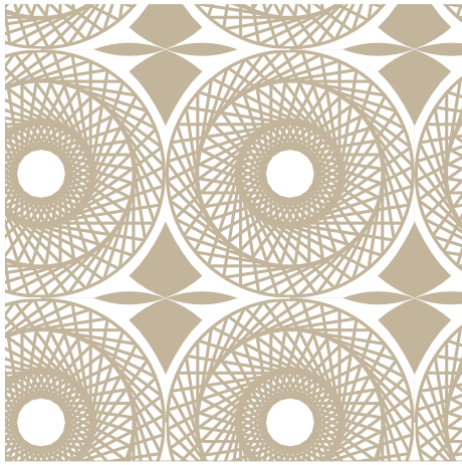

SER-01

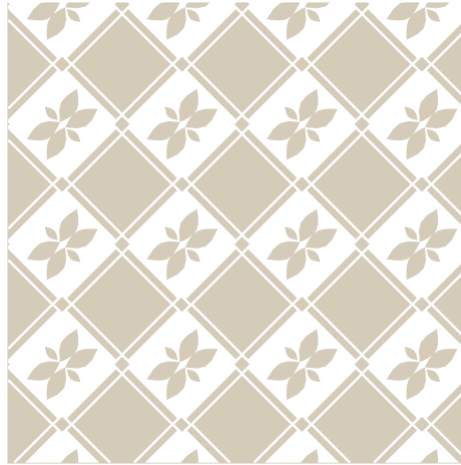

SER-02

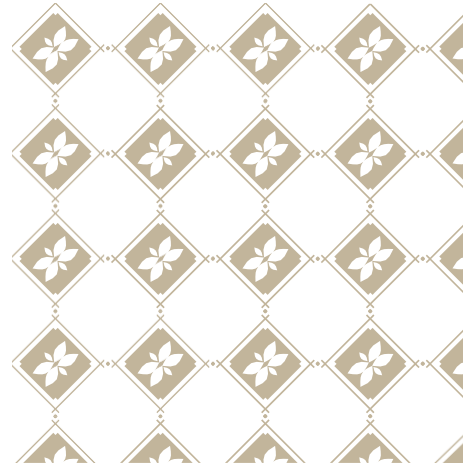

SER-03



SER-04



SER-05

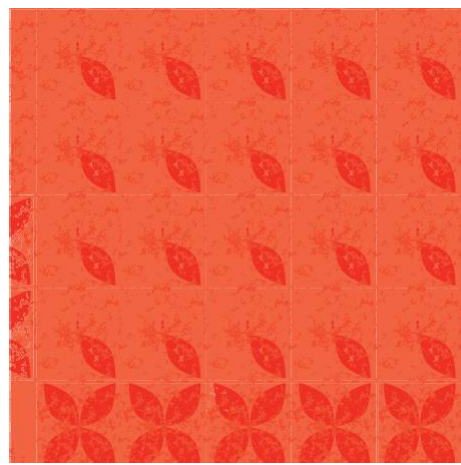

SER-06

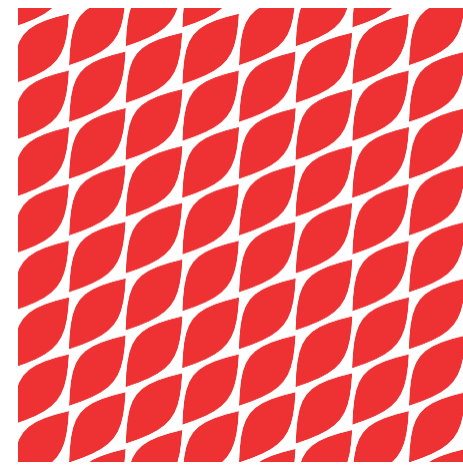

SER-07

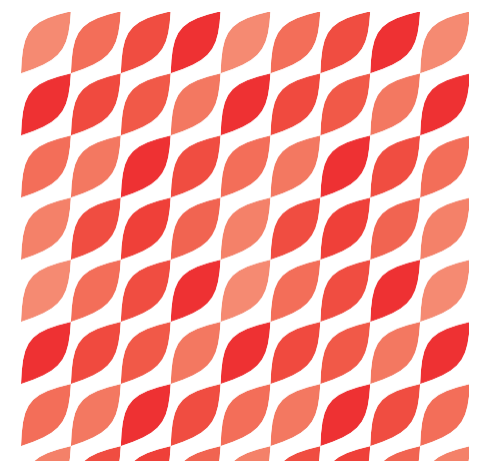

SER-08

M² de superficie serigrafiada	
Screen Print SQM surface	38000
M ² de surface sérigraphiée	

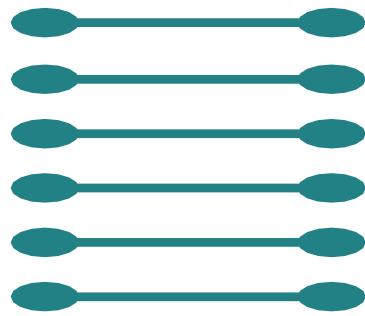

COMPLEMENTOS Y EQUIPAMIENTO

Complements and Equipments
Compléments et Équipement



CONTENEDOR / BIG DRAWER / TIROIR

Cajón de extracción total con freno y autocierre Hettich, con laterales y correderas metálicas. Fondo de cajón 350 mm, espacio útil en altura 170 mm. 3 colores a elegir al realizar su pedido.

Full extension, soft and self close drawer from Hettich. It has metallic runners and side. 350 mm deep drawers, useful space in height of 170 mm. 3 colours to choose when placing your order.
Tiroir à sortie totale avec amortisseur et fermeture automatique Hettich, latéraux et coulisses métalliques. Profondeur du tiroir 350 mm, hauteur utile 170 mm. 3 coloris à choisir à la commande.



CAJÓN INTERIOR / INTERIOR DRAWER / TIROIR À L'ANGLAISE

Cajón de extracción total con freno y autocierre Hettich, con laterales y correderas metálicas. Fondo de cajón 350 mm, espacio útil en altura 90 mm. 3 colores a elegir al realizar su pedido.

Full extension, soft and self close drawer from Hettich. It has metallic runners and side. 350 mm deep drawers, useful space in height of 90 mm. 3 colours to choose when placing your order.
Tiroir à sortie totale avec amortisseur et fermeture automatique Hettich, latéraux et coulisses métalliques. Profondeur du tiroir 350 mm, hauteur utile 90 mm. 3 coloris à choisir à la commande.



CAJONES DE MADERA Serie MIMOSA / SOFT CLOSE WOODEN DRAWERS MIMOSA Series/ TIROIRS EN BOIS Série MIMOSA



95 MM

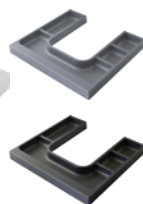

1763



116 MM



1552



216 MM



1552

COMPLEMENTOS DE CAJÓN / DRAWER'S COMPLEMENTS / ACCESSOIRES DE TIROIR



60 CM



70 CM



80 CM



90 CM



100 CM



120 CM

Múltiples combinaciones. / Multiple combinations. / Combinaisons multiples.



SALVASIFÓN DE 3 PIEZAS
/ 3 PART TRAP PROTECTION
/ CACHE SIPHON 3 SECTIONS

1006

VÁLVULA CLICK CLACK CROMO
/ CLICK-CLACK VALVE
/ BONDE CLIC CLAC CHROME



2.534

SIFÓN PVC BLANCO
/ PVC WHITE TRAP
/ SIPHON PVC BLANC



1.151

* El grifo, el sifón del lavabo y la válvula no están incluidos en ninguna de las series.
* The faucet, trap and the valve are never included in any series.
* Ni le mitigeur, ni la bonde, ni le siphon ne sont inclus dans les séries de ce catalogue.



SALVASIFÓN CURVO
/ CURVED TRAP PROTECTION / CACHE SIPHON COURBE

Salvasifón de PVC con forma curva en la parte delantera centrado en el cajón, ancho de cala 120 mm y fondo de cala total 260 mm con un radio de 60 mm. De uso exclusivo para muebles con menos de 35 cm de fondo.

PVC Trap protection of curved shape in the front part, located in the centre of the drawer. Width of the trap cut of 120 mm and total depth of 260 mm, with a radius of 60 mm.

Cache siphon en PVC, forme courbe sur l'avant, centré sur la largeur du tiroir. Largeur de la découpe 120 mm, profondeur de la découpe 260 mm, rayon de 60 mm. Uniquement pour les meubles de profondeur inférieure à 35 cm.



BISAGRA FRENO 90º
/ SOFT CLOSE HINGE 90º
/ CHARNIÈRE FREIN 90º

Bisagra metálica, niquelada, con freno incorporado con ajuste cómodo de la profundidad con espiral, montaje y desmontaje sin herramientas de la puerta en el cuerpo del mueble. Ajuste en 3 dimensiones

Metal hinge, nickel plated, with integrated soft close mechanism. Comfortable adjustment of the depth, assembly and disassembly of the door without tools. 3-Dimensional adjustment.

Charnière métallique, nickelée, avec frein incorporé. Réglage facile de la profondeur avec spirale. Montage et démontage sans outil. Réglage en 3 dimensions.



COLGADOR SCARPI
SCARPI HANGER SET
SUSPENSION SCARPI

Metálico.
Soporte de 65 kg/ unidad.

Metallic.
65 kg supported by unit.

Métallique.
Supporte 65 kg chacun.



COLGADOR OCULTO
HIDDEN HANGER SET
SUSPENSION INVISIBLE

Para módulos auxiliares.
Soporte de 65 kg/ unidad.

For auxiliary units.
65 kg supported by unit.

Pour les meubles auxiliaires.
Supporte 65 kg chacun.

JUEGO DE PATAS (4 unidades) / LEGS SET (4 units) / JEU DE PIEDS (4 unités)



PATA CUADRADA 10 CM
SQUARE LEG 10 CM
PIED CARRÉ 10 CM



PATA CUADRADA 12 CM
SQUARE LEG 12 CM
PIED CARRÉ 12 CM



PATA CUADRADA 20 CM
SQUARE LEG 20 CM
PIED CARRÉ 20 CM



ACABADO BRILLO
GLOSSY FINISH
FINITION BRILLANT



ACABADO MATE
MATT FINISH
FINITION MAT



ELEVADOR ACABADO BRILLO
SMALL ELEVATORS GLOSSY FINISH
PETIT PIED FINITION BRILLANT

35 x 100 x 35	Brillo Glossy / Brillant	35 x 120 x 35	Brillo Glossy / Brillant	Mate Matt / Mat	35 x 200 x 35	Mate Matt / Mat		80 x 30 x 80	
								100 x 20 x 100	

ESPEJOS / MIRRORS / MIROIRS

MEDIDAS (Alto x Ancho)
MEASUREMENTS (Height x Width)
DIMENSIONS (Hauteur x Largeur)

Especificar posición horizontal o vertical
Specify horizontal or vertical position Préciser
la position (horizontale ou verticale)



LUNA DE CRISTAL
4 MM MIRROR
MIROIR 4 MM



LISO
16MM PANEL W/ MIRROR
MIROIR SUR PANNEAU



OVAL HORIZONTAL
OVAL HORIZONTAL
OVAL HORIZONTAL



OVAL VERTICAL
OVAL VERTICAL
OVAL VERTICAL



REDONDO
ROUND
ROND



RECTANGULAR
RECTANGULAR
RECTANGULAIRE

800 x 600		800 x 600		600 x 700		700 x 600		600 x 600		1200 x 400
800 x 700		800 x 700		600 x 800		800 x 600		800 x 800		
800 x 800		800 x 800		600 x 900		900 x 600				
800 x 900		800 x 900		600 x 1000		1000 x 600				
800 x 1000		800 x 1000		800 x 1000		1000 x 800				
800 x 1200		800 x 1200								



ESPEJO CON TABLERO
MIRROR WITH PANEL
MIROIR SUR PANNEAU

GRUPO
GROUP
GROUPE
A

GRUPO
GROUP
GROUPE
B

GRUPO
GROUP
GROUPE
C

LACA
Mate y Texturado
MATT LACQUER (and Textured)
LAQUE Mate et avec texture

LACA
Brillo y Engomado
GLOSSY LACQUER (and Rubber finish)
LAQUE Brillant et effet gomme

700 x 600	
700 x 700	
700 x 800	
700 x 900	
700 x 1000	
700 x 1200	

Los precios son los mismos para el espejo doble horizontal, doble vertical, enmarcado, simple vertical y simple horizontal.

The prices are same for the Double Horizontal, Double Vertical, Framed, Simple Horizontal and Simple Vertical Mirrors.

Les prix sont les mêmes pour le miroir double horizontal, double vertical, avec cadre, simple vertical et simple horizontal.

ACCESORIO ANTIVAHO
ANTI-CONDENSATION ACCESSORY / ACCESSOIRE ANTI-BUÉE

LAVABOS / BASINS / VASQUES

LAVABO CERÁMICO

CERAMIC BASIN
VASQUE CÉRAMIQUE

MEDIDAS (Ancho x Fondo)
MEASUREMENTS (Width x Depth)
DIMENSIONS (Largeur x Profondeur)

610 x 460
710 x 460
710 x 460 seno izquierda / left bowl / Vasque à gauche
810 x 460
810 x 460 seno izquierda / left bowl / Vasque à gauche
910 x 460
910 x 460 seno izquierda / left bowl / Vasque à gauche
1010 x 460
1010x460 seno izquierda / left bowl / Vasque à gauche
1210 x 460 1 seno / 1 bowl / vasque simple
1210x460 seno izquierda / left bowl / Vasque à gauche
1210 x 460 2 senos / 2 bowl / vasque double

Tolerancia de +6 mm
Su uso no es indicado en espacios justos de medida.
Tolerance of +6 mm
It is not recommended for tight fitting spaces.
Tolérance de +6mm
Non recommandé pour les espaces de dimensions ajustées



Seno desplazado a izquierda
Left side bowl
Vasque décentrée à gauche

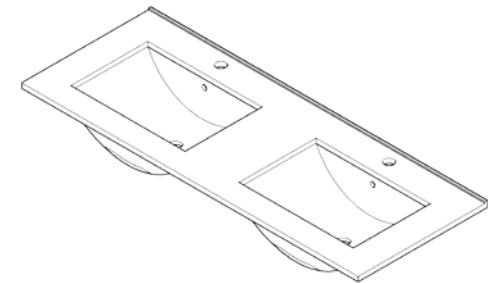
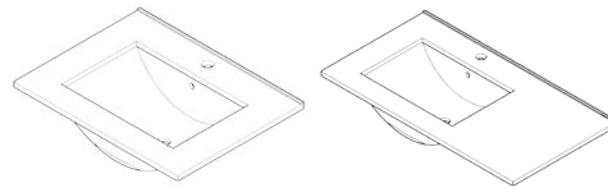

1 SENO / 1 BOWL / VASQUE SIMPLE

2 SENOS / 2 BOWLS / VASQUE DOUBLE

Vista superior
Upper view
Vue de haut

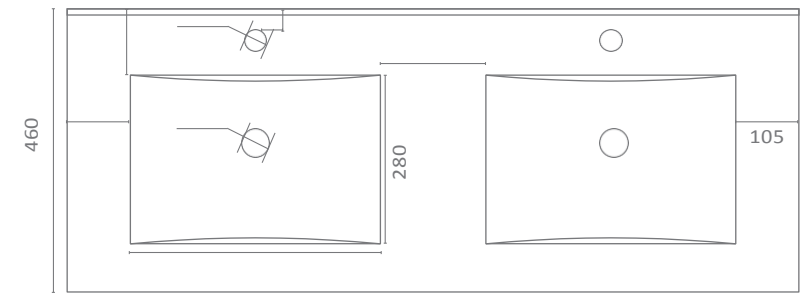
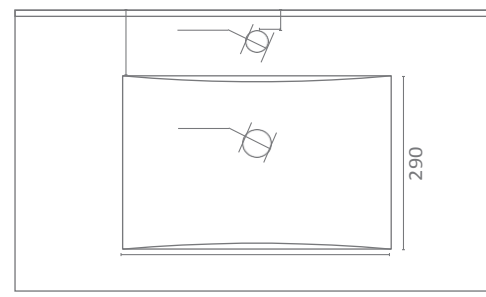
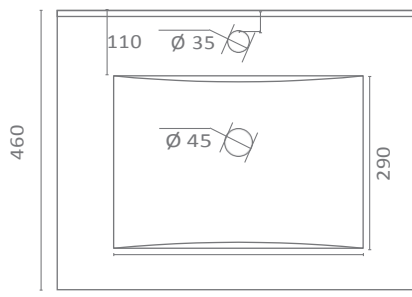

Vista inferior
Lower view
Vue d'en bas

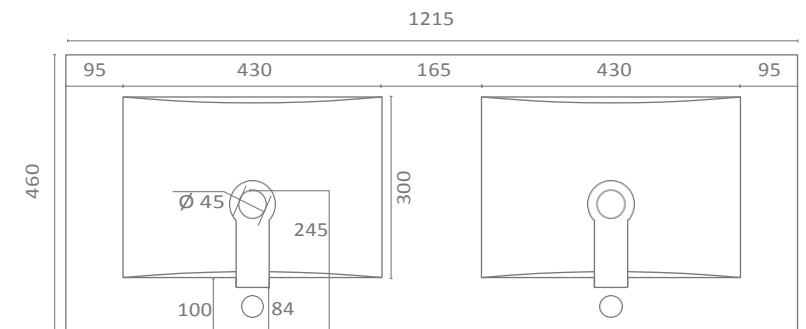
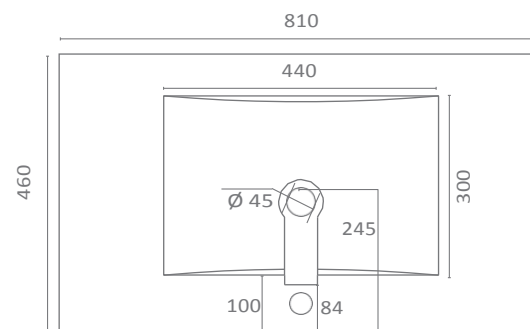
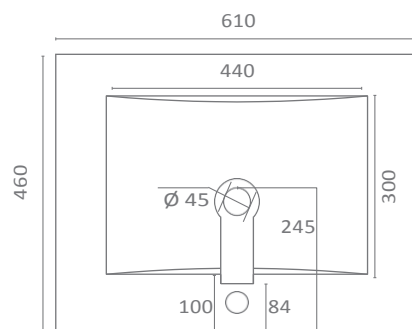

Vista frontal
Front view
Vue de face

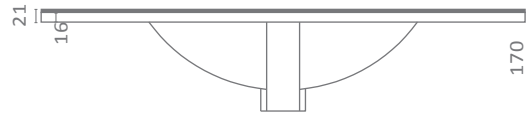
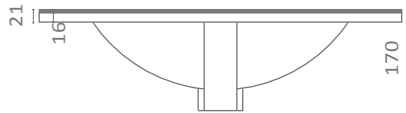

LAVABO RESINA

RESIN BASIN
VASQUE RÉSINE



Su uso no es indicado en espacios justos de medida.

It is not recommended for tight fitting spaces.

Non recommandé pour les espaces de dimensions ajustées.

MEDIDAS (Ancho x Fondo)

MEASUREMENTS (Width x Depth)

DIMENSIONS (Largeur x Profondeur)

1 SENO / 1 BOWL / VASQUE SIMPLE

2 SENOS / 2 BOWLS / VASQUE DOUBLE

610 x 464

710 x 464

810 x 464

910 x 464

1010 x 464

2 senos
2 bowl
vasque double

1210 x 464

Perspectiva
Perspective
Perspective

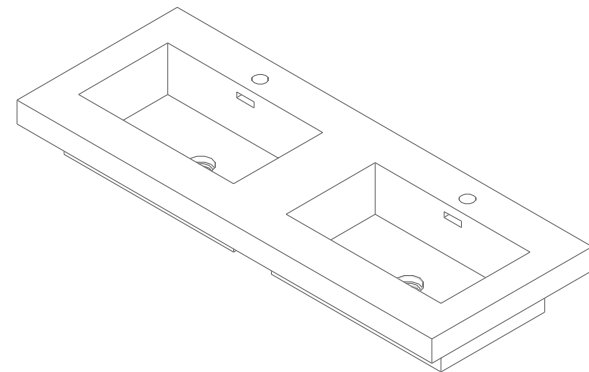
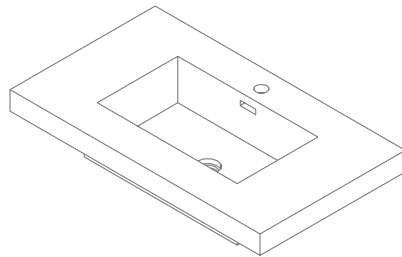

Vista superior
Upper view
Vue de haut

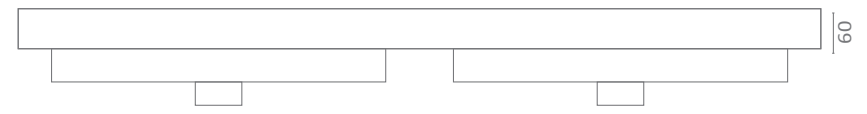
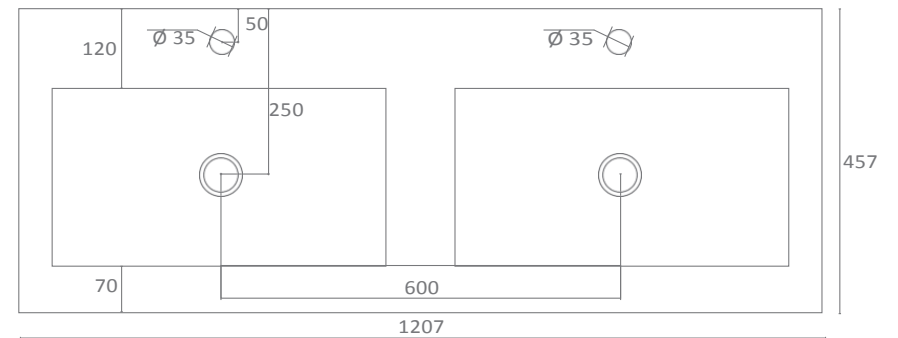
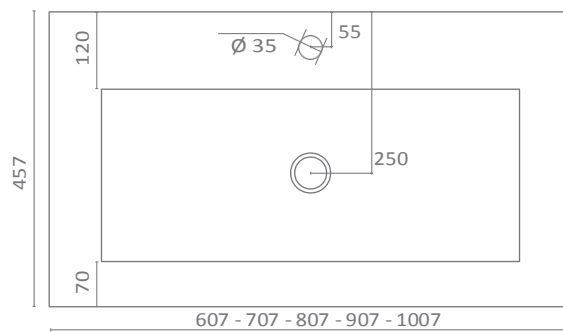

Vista frontal
Front view
Vue de face

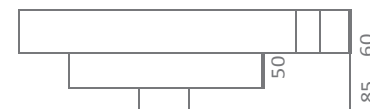

LAVABO CRISTAL

GLASS BASIN
VASQUE VERRE



Su uso no es indicado en espacios justos de medida.

It is not recommended for tight fitting spaces.

Non recommandé pour les espaces de dimensions ajustées.

COLORES COLOURS COLORIS



MEDIDAS (Ancho x Fondo)

MEASUREMENTS (Width x Depth)

DIMENSIONS (Largeur x Profondeur)

1 SENO / 1 BOWL / VASQUE SIMPLE

2 SENOS / 2 BOWLS / VASQUE DOUBLE

610 x 464		
710 x 464		
810 x 464		
910 x 464		
1010 x 464		
	1 seno 1 bowl vasque simple	2 senos 2 bowl vasque double
1210 x 464	22.543	31.824

Vista superior
Upper view
Vue de haut

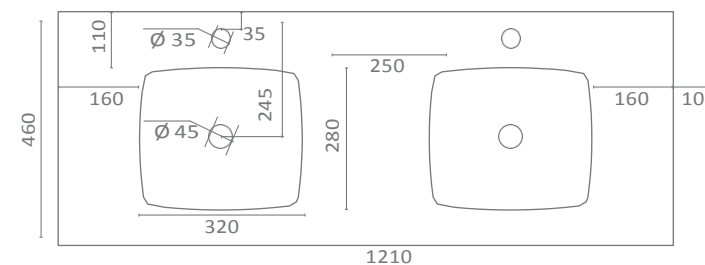
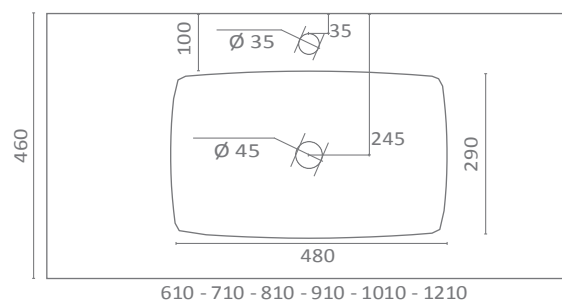

Vista frontal
Front view
Vue de face



Vista superior
Upper view
Vue de haut

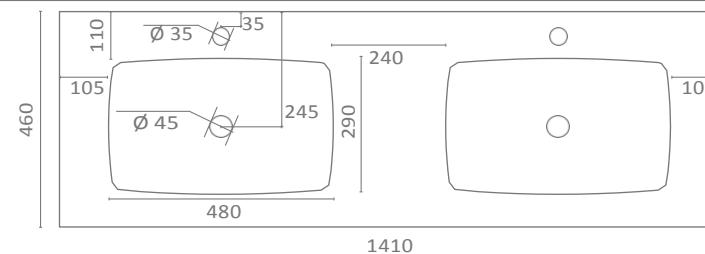

Vista frontal
Front view
Vue de face



TIRADORES / HANDLES / POIGNÉES

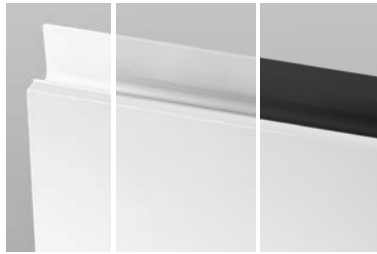

T22

Este tirador solo se puede aplicar a las siguientes series:
 This handle is only applicable to the following series:
 Cette poignée ne peut être appliquée qu'aux séries suivantes

ARTEMIS - CUBO - BEATRIZ - BIANCA
 DAVO - ON - TAO

El precio se incrementa en los siguientes puntos:
 The price increases in these points:
 La plus-value est de (en points).

Medidas de puerta - Door's measure - Dimensions de la porte

400 mm	500 mm	600 mm	700 mm	800 mm	900 mm	1000 mm	1200 mm
-----------	-----------	-----------	-----------	-----------	-----------	------------	------------

Los siguientes tiradores se pueden aplicar a todas las series de muebles sin incremento de precio.

These handles can be applied to all series and units without any price increment.

Les poignées suivantes peuvent être appliquées à toutes les séries de meubles sans plus-value.

ESTÁNDAR



B005

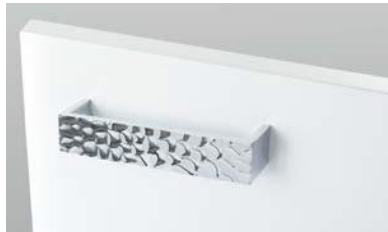

A30



A31



A32



C5



T104



T110



T113



T114



T115



T116



T117



T123



T124



T999



FOCOS / SPOTLIGHT / APPLIQUES

MODELO / MODEL / MODÈLE



0003
S/TRAFO
250 CR

INST.

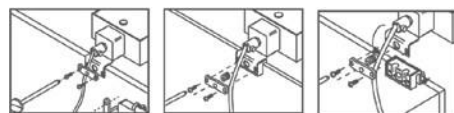

S3.Marco de madera S4.Espejo

MODELO / MODEL / MODÈLE



0004
C/TRAFO
554 AL-CR
Espejos
Mirrors / Miroirs
> 600 mm.

INST.

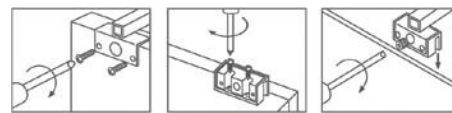

S3.Marco de madera S2.Camerino S2.Camerino S2.Camerino

MODELO / MODEL / MODÈLE



0006
S/TRAFO
253 CR

INST.

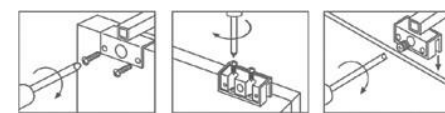

S3.Marco de madera S2.Camerino S4.Espejo

MODELO / MODEL / MODÈLE



0009
C/TRAFO
CR

INST.

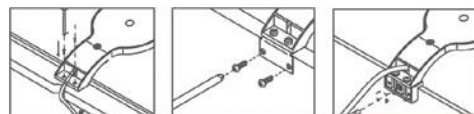

S2.Camerino S3.Marco de madera S4.Espejo

MODELO / MODEL / MODÈLE



0010
S/TRAFO
CR

INST.

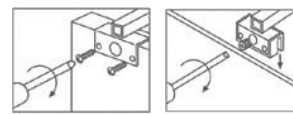

S3.Marco de madera S4.Espejo

MODELO / MODEL / MODÈLE



0011
S/TRAFO
CR

INST.

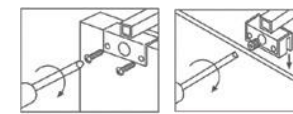

S3.Marco de madera S4.Espejo

MODELO / MODEL / MODÈLE



0025
S/TRAFO
225 CR
LED

INST.

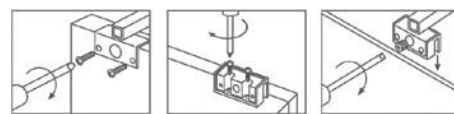

S3.Marco de madera S2.Camerino S4.Espejo

MODELO / MODEL / MODÈLE



0026
S/TRAFO
300 CR
LED

INST.

MODELO / MODEL / MODÈLE



ESTHER
LED 6W

L. 28 CM L. 49,4 CM



469

Todos nuestros focos están preparados para espejo sobre tablero. Para colocarlos en Luna de Cristal o Camerino es imprescindible solicitar el **ADAPTADOR**

All our spotlights are prepared for mirror with panel. To put it on 4mm Mirror or Mirror Wall Unit it is mandatory to order an **ADAPTOR**

Toutes nos appliques sont adaptées aux miroirs sur panneau. Pour les monter sur un miroir de 4 mm ou sur un meuble, il est obligatoire de commander un **ADAPTATEUR**

PAG
10



DESCRIPCIÓN AFRODITA	DESCRIPTION	DESCRIPTION
Mueble 1000 1C S/Patas (Laca Mate Habano)	Unit	Meuble
Lavabo Nettuno 550	Nettuno Basin	Vasque Nettuno
Espejo Oval 800X1000	Oval Mirror	Miroir oval
TOTAL	TOTAL SET	TOTAL ENSEMBLE
½ Columna Afrodita 410 2C S/PATAS	Semi Column Hanged with two big vertical drawers	Demi colonne suspendue avec deux tiroirs verticaux
TOTAL	TOTAL	TOTAL

PAG
11



DESCRIPCIÓN AFRODITA	DESCRIPTION	DESCRIPTION
Mueble 800 1C C/Patas (Laca Mate Blanco)	Unit	Meuble
Lavabo Nettuno 550	Nettuno Basin	Vasque Nettuno
Espejo Oval 800X1000	Oval Mirror	Miroir oval
TOTAL	TOTAL SET	TOTAL ENSEMBLE
½ Columna Afrodita 410 2C C/PATAS	Semi Column with legs and with 2 vertical big drawers	Demi colonne avec pieds avec deux tiroirs verticaux
TOTAL	TOTAL	TOTAL

PAG
14



DESCRIPCIÓN ARTEMIS	DESCRIPTION	DESCRIPTION
Mueble 700 2P (Grupo B Cuatro 3091)	Unit	Meuble
Lavabo Naos 720	Naos Basin	Vasque Naos
Espejo Doble Horizontal De 700	Double Horizontal Mirror	Miroir double horizontal
Foco S/TRAFO 006	Spotlight	Applique S/TRAFO 006
TOTAL	TOTAL SET	TOTAL ENSEMBLE
Media Columna de dos puertas 350x1600x250	Semi Column 2 doors	Demi colonne 2 portes
TOTAL	TOTAL	TOTAL

PAG
15



DESCRIPCIÓN ARTEMIS	DESCRIPTION	DESCRIPTION
Mueble 900 2P (Grupo B Seissa 1102)	Unit	Meuble
Lavabo Naos 900	Naos Basin	Vasque Naos
Espejo Enmarcado De 900	Framed Mirror	Miroir avec cadre
2 Foco 0011 S/Trafo Cr	2 Spotlights	2 Appliques 0011
TOTAL	TOTAL SET	TOTAL ENSEMBLE
Media Columna de dos puertas 350x1600x250	Semi Column 2 doors	Demi colonne 2 portes
TOTAL	TOTAL	TOTAL

PAG
18



DESCRIPCIÓN ATENEA	DESCRIPTION	DESCRIPTION
Mueble 600 1C (Laca Mate Piedra)	Unit	Meuble
Lavabo Cerámico 600	Quartz Basin	Vasque Compacto
Espejo Doble Listón De 600	Double Horizontal Mirror	Miroir double horizontal
Foco Esther L494	Spotlight Esther	Applique LED Esther
TOTAL	TOTAL SET	TOTAL ENSEMBLE
Media Columna 350x760x370	Semi Column	Demi colonne

PAG
19



DESCRIPCIÓN ATENEA	DESCRIPTION	DESCRIPTION
Mueble 800 1C (Laca Brillo Negro)	Unit	Meuble
Lavabo Cerámico 800	Quartz Basin 800	Vasque Céramique
Espejo Liso De 800 X 800	16mm Panel Mirror	Miroir lisse
Foco Esther L494	Spotlight Esther	Applique LED Esther
Total	TOTAL SET	TOTAL ENSEMBLE
Media Columna 350X760x370	Semi Column	Demi colonne

PAG
22



DESCRIPCIÓN CUBO	DESCRIPTION	DESCRIPTION
1 Tapa De 1200 (Grupo A Mecuo 93)	1 Top (Mecuo 93) With cut.	1 Plateau de meuble (Mecuo 93) avec découpe pour vasque
1 Tapa De 1200 (Grupo B Seissa 1100)	1 Top (Seissa 1100)	1 Plateau de meuble (Seissa 1100)
2 Mueble Cubo 600 (Grupo A Mecuo 93-T22)	2 Units (Mecuo 93-T22)	2 Meubles (Mecuo 93 - Poignée T22)
2 Mueble Cubo 600 (Grupo B Seissa 1100-T22)	2 Units (Seissa 1100-T22)	2 Meubles (Seissa 1100 - Poignée T22)
Lavabo Nettuno 550	Nettuno Basin	Vasque Nettuno
Luna De Cristal De 800X1200	4mm Mirror	Miroir 4 mm
Esther Led 494 Mm	Spotlight Esther	Applique LED Esther
Juego De Patas 80X80 Altura 30	Legs set	Jeu de pieds
TOTAL	TOTAL SET	TOTAL ENSEMBLE
Decorativo Vertical Rectángulo (Grupo A Mecuo 93)		(Mecuo 93)
Decorativo Horizontal Rectángulo (Grupo A Mecuo 93)	Decorative horizontal rectangle (Mecuo 93)	Meuble s. porte horizontal rectangulaire (Mecuo 93)
Decorativo 1 Cubo (Grupo B Seissa 1100)	Decorative 1 Cubo (Seissa 1100)	Meuble s. porte 1 cube (Seissa 1100)

PAG
23



DESCRIPCIÓN CUBO	DESCRIPTION	DESCRIPTION
2 Tapa de 1000 (Laca Platino mate)	2 Tops One with cut.	2 Plateaux de meuble avec 1 découpe pour vasque
2 Mueble Cubo 600 (Grupo B Meidass 41-T22)	2 UNITS 600	2 Meubles 600
2 Mueble Cubo 400 (Grupo B Meidass41-T22)	2 UNITS 400	2 Meubles 400
Lavabo Nettuno 550	Nettuno Basin	Vasque Nettuno
Espejo redondo 800x800	Round Mirror	Miroir rond
TOTAL	TOTAL SET	TOTAL ENSEMBLE
2 Columna 400 2 Puertas Suspendido (Laca Platino Mate-T22)	2 Semi Column 400	2 Demi colonnes 400
Decorativo Vertical 3 Cubos 200X600 (Laca Platino Mate)	Decorative vertical 3 Cubos	Meuble décoratif vertical 3 cubes

PAG
26



DESCRIPCIÓN HERA	DESCRIPTION	DESCRIPTION
Mueble Hera 900 C600+P300 (Grupo B Mod. Bernini)	Unit	Meuble
Lavabo Nettuno 550	Nettuno Basin	Vasque Nettuno
Espejo Rectangular	Mirror	Miroir
TOTAL	TOTAL SET	TOTAL ENSEMBLE
Colgar De 300X600x255 Grupo B Modelo Bernini	Wall Unit	Meuble haut suspendu

PAG
27



DESCRIPCIÓN HERA	DESCRIPTION	DESCRIPTION
Mueble Hera 900 C600+P300 (Grupo C Modelo Bennu 007 Con Tapa Bernini)	Unit	Meuble
Lavabo Nettuno 550	Nettuno Basin	Vasque Nettuno
Espejo Rectangular	Mirror	Miroir
TOTAL	TOTAL SET	TOTAL ENSEMBLE
Colgar De 300X600x255 Grupo C Modelo Bennu7	Wall Unit	Meuble haut suspendu

PAG
30



DESCRIPCIÓN MIMOSA	DESCRIPTION	DESCRIPTION
Mueble Con 1P 600 (Toffee LPA) Y 1 Cajón De Madera Con Salva Sifón	Unit	Meuble
Lavabo De Resina	Basin	Vasque
Marco Con Espejo Ovalado Y Repisa Con Duelas Para Mueble De 600	Mirror	Miroir
TOTAL CONJUNTO	TOTAL SET	TOTAL ENSEMBLE
Toallero Con 2 Baldas Decorativas	Towel rack Unit	Meuble porte-serviette
Columna Con 1P Vitrina Ovalada, 2 Cajones De Ma- dera Y 2 Baldas Cristal	Column 1 door and 2 drawers	Colonne 1 porte et 2 tiroirs

PAG
31



DESCRIPCIÓN MIMOSA	DESCRIPTION	DESCRIPTION
Mueble Con 1P 600 (Verdoso LPA) Y 1 Cajón De Madera Con Salva Sifón	Unit	Meuble
Lavabo De Resina	Basin	Vasque
Marco Con Espejo Ovalado Y Repisa Con Duelas Para Mueble De 600	Mirror	Miroir
TOTAL CONJUNTO	TOTAL SET	TOTAL ENSEMBLE
Toallero Con 2 Baldas Decorativas	Towel rack Unit	Meuble porte-serviette
Columna Con 1P Vitrina Ovalada, 2 Cajones De Ma- dera Y 2 Baldas Cristal	Column 1 door and 2 drawers	Colonne 1 porte et 2 tiroirs

PAG
36



DESCRIPCIÓN BEATRIZ	DESCRIPTION	DESCRIPTION
Mueble Beatriz 1000 (Grupo C Bennu 05)	Unit	Meuble
Lavabo Cerámico 1000	Ceramic Basin	Vasque céramique
Espejo Redondo 800X800	Round Mirror	Miroir 4 mm
TOTAL	TOTAL SET	TOTAL ENSEMBLE

PAG
37



DESCRIPCIÓN BEATRIZ	DESCRIPTION	DESCRIPTION
Mueble Beatriz 600 (Grupo B Metzia 071)	Unit	Meuble
Lavabo Cerámico 600	Ceramic Basin	Vasque céramique
Luna De Cristal De 800 X 600	4mm Mirror	Miroir 4 mm
TOTAL	TOTAL SET	TOTAL ENSEMBLE

PAG 40		DESCRIPCIÓN	DESCRIPTION	DESCRIPTION
		Mueble Bianca 1200 suspendido con un cajón, un contenedor y puerta con balda (GRUPO B SEISSA 1102)	Unit Bianca	Meuble Bianca
		Lavabo cerámico 1200 doble seno	Ceramic Basin Double Bowl	Vasque céramique double
		Luna de cristal de 800 x 800	4mm Mirror	Miroir 4 mm
		TOTAL	TOTAL SET	TOTAL ENSEMBLE
PAG 41		DESCRIPCIÓN	DESCRIPTION	DESCRIPTION
		Mueble Bianca Total 1200 suspendido con dos cajones y dos contenedores (GRUPO A MERCURIO 20)	Unit Bianca	Meuble Bianca Total
		Lavabo cerámico 1200 doble seno	Ceramic Basin Double Bowl	Vasque céramique double
		Luna de cristal de 800 x 800	4mm Mirror	Miroir 4 mm
		TOTAL	TOTAL SET	TOTAL ENSEMBLE
PAG 44		DESCRIPCIÓN	DESCRIPTION	DESCRIPTION
		Mueble CARLA 800 un cajón, un contenedor y una puerta (GRUPO B METZIA 71-SEISSA 1102)	Unit	Meuble
		Lavabo cerámico 800	Ceramic Basin	Vasque céramique
		Espejo Enmarcado de 700x800	Framed Mirror	Miroir avec cadre
		TOTAL	TOTAL SET	TOTAL ENSEMBLE
PAG 45		DESCRIPCIÓN	DESCRIPTION	DESCRIPTION
		Mueble CARLA de 700 un cajón, un contenedor y una puerta (ACABADO GRUPO A PETRONAS 81-82)	Unit	Meuble
		Lavabo cerámico 700	Ceramic Basin	Vasque céramique
		Luna de cristal de 800x700	4mm Mirror	Miroir 4 mm
		TOTAL	TOTAL SET	TOTAL ENSEMBLE
PAG 48		DESCRIPCIÓN	DESCRIPTION	DESCRIPTION
		Mueble Davo 800 (Grupo B Meidass 41-43)	Unit Davo	Meuble Davo Linéaire
		Lavabo Cerámico 800	Ceramic Basin 800	Vasque Céramique 800
		Espejo Enmarcado 700 X 800	16Mm Panel Mirror	Miroir Double Horizontal
		TOTAL	TOTAL SET	TOTAL ENSEMBLE
PAG 49		DESCRIPCIÓN	DESCRIPTION	DESCRIPTION
		Colgar 350X600x250 (Grupo B Meidass 41-43)	Total Set	Total Ensemble
		2 Media Columna De 350X1200 (Grupo B Seissa 1101)	Semi Column 2 Doors	Demi Colonne 2 Portes
		DESCRIPCIÓN	DESCRIPTION	DESCRIPTION
		Mueble Davo Lineal 1000 (Acabado Grupo A Cuero 01)	Unit Davo Lineal	Meuble Davo linéaire
Lavabo Cerámico 1000	Ceramic Basin 1000	Vasque céramique 1000		
Espejo Liso De 800X800	16mm Panel Mirror	Miroir 4 mm		
TOTAL	TOTAL SET	TOTAL ENSEMBLE		

PAG
52



DESCRIPCIÓN	DESCRIPTION	DESCRIPTION
Mueble ON 600 (GRUPO B METZIA 73)	Unit	Meuble
Lavabo cristal 600	Glass Basin	Vasque Verre
Luna de cristal de 800 x 600	4mm Mirror	Miroir 4 mm
TOTAL	TOTAL SET	TOTAL ENSEMBLE

PAG
53



DESCRIPCIÓN	DESCRIPTION	DESCRIPTION
Mueble On 1000 (Grupo A Mecuo 90)	Unit	Meuble
Lavabo Cerámico 1000	Ceramic Basin	Vasque Céramique
Espejo Enmarcado De 700X1000	Framed Mirror	Miroir Avec Cadre
TOTAL	TOTAL SET	TOTAL ENSEMBLE

PAG
56



DESCRIPCIÓN	DESCRIPTION	DESCRIPTION
Mueble Tao 1000 (Grupo B Cuatro 100)	Unit	Meuble Tao
Lavabo Cerámico 1000	Ceramic Basin	Vasque Céramique
Espejo Doble Horizontal De 700 X 900	Double Mirror	Miroir Double Horizontal
TOTAL	TOTAL SET	TOTAL ENSEMBLE

PAG
56



DESCRIPCIÓN	DESCRIPTION	DESCRIPTION
Mueble Tao 600-Tirador Uñero T22 (Grupo A Madagascar 64)	Unit	Meuble Tao avec prise de main
Lavabo Cerámico 600	Ceramic Basin	Vasque céramique
Luna De Cristal De 800X600	4mm Mirror	Miroir 4 mm
TOTAL	TOTAL SET	TOTAL ENSEMBLE

PAG
57



DESCRIPCIÓN	DESCRIPTION	DESCRIPTION
Mueble Tao Gola De 800 (Acabado Grupo A Mercurio 008)	Unit	Meuble Tao Gola
Lavabo Cerámico 800	Ceramic Basin	Vasque céramique
Luna De Cristal De 800 X 800	4mm Mirror	Miroir 4 mm
TOTAL	TOTAL SET	TOTAL ENSEMBLE
Media Columna 350x1400x250 2P Gola Suspendido	Semi Column Gola	Demi colonne Gola

